

**PREVIOUS
MENU**

FORD AOD-E

GO TO PAGE

DESCRIPTION	3
OPERATION SENSORS	5
DIAGNOSIS	16
DIAGNOSTIC ROUTINES	41
DISASSEMBLY / ASSEMBLY	68
SUB ASSEMBLIES	80
VALVE BODY.....	109
SPECIFICATIIONS	112

**Automatic Transmission Service Group
9200 South Dadeland Blvd.
Suite 720
Miami, FL 33156
(305) 661-4161**



INTRODUCTION FORD AOD-E

The AOD-E transmission is a four speed, rear wheel drive automatic overdrive transmission which is computer controlled. This unit has a converter clutch. In its general appearance it resembles the hydraulically controlled AOD transmission. This unit has two different shafts at the front where as the AOD has three this, will be a quick way to identify the units. This manual gives the electrical diagnosing methods for this unit. You will notice that there are several pieces of diagnosing equipment that will be necessary for quick accurate diagnosing. The teardown and assembly is covered in this manual.

**We thank the Ford Motor Company
for the illustrations and information
that made this booklet possible**

The information and part numbers contained in this booklet have been carefully compiled from industry sources known for their reliability, but ATSG does not guarantee its accuracy.

**ROBERT D. CHERRNAY
TECHNICAL DIRECTOR**

**WAYNE COLONNA
TECHNICAL SUPERVISOR**

**DALE ENGLAND
FIELD SERVICE CONSULTANT**

**FRANK MIETUS
TECHNICAL CONSULTANT**

**ED KRUSE
LAY OUT**

***AUTOMATIC TRANSMISSION SERVICE GROUP
9200 SOUTH DADELAND BLVD.
SUITE 720
MIAMI, FLORIDA 33156
(305) 670-4161***



Technical Service Information

DESCRIPTION

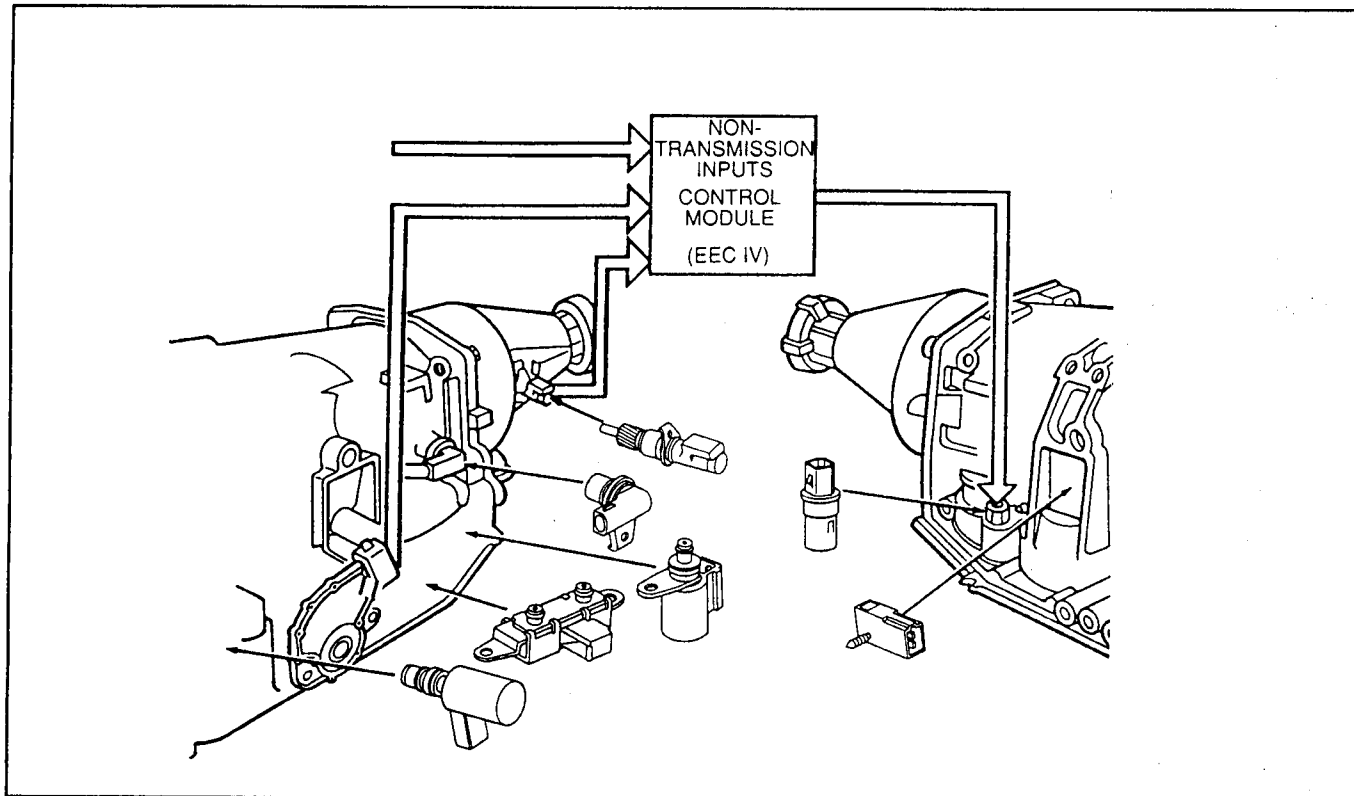

Selector and Shift Patterns

The AOD-E shift selector has six positions, ordered as follows: P,R,N,Ⓞ,D and 1.

(P) Park

There is no powerflow through the transmission in PARK range. The parking pawl locks to the output shaft to the case to prevent the vehicle from rolling. However, for safety reasons, the vehicle parking brake should also be used when the vehicle is parked and not in use. The engine can be started in the PARK range. In addition, PARK must be selected before the ignition key can be removed.

(R) Reverse

Reverse gear enables the vehicle to be operated in a rearward direction, at a reduced ratio. There is engine braking in reverse, provided by the low-reverse (planetary) one-way clutch.

(N) Neutral

There is no powerflow through the transmission in NEUTRAL. However, the vehicle's wheels are free to move because the output shaft is not held by the parking pawl. The engine may be started in NEUTRAL, but the ignition key cannot be removed while the vehicle is in this range.

(Ⓞ) Overdrive

Overdrive is the normal selector position for most forward driving conditions. This position provides all automatic shifts, application and release of the torque converter clutch and maximum fuel economy during normal operation.

(D) Drive

Selection of the DRIVE position provides all automatic shifts except into fourth gear (OVERDRIVE). Application of the converter clutch may also occur in this range, depending on transmission and vehicle conditions. This position can be selected when overdrive is not wanted, such as driving in hilly or mountainous terrain, going into a strong headwind or towing a trailer.

(1) Manual Low

Selection of MANUAL LOW position at idle will allow first gear operation only (no upshifts). If this position is selected at normal road speeds, the transmission will initially downshift into second gear, then downshift into first gear when vehicle speed falls below approximately 45 km/h (28 mph).



Technical Service Information

The MANUAL LOW position will provide engine braking, making it especially useful for descending steep grades.



TRANSMISSION
SELECTOR
INDICATOR

OPERATION

Torque Converter

The torque converter for the AOD-E is a four-element converter. It contains the standard three elements (impeller, turbine and stator) for transmission and multiplication of torque, plus a torque converter clutch for increased fuel economy in third and fourth gears.

The operation of the main torque converter components is as follows:

- Rotation of the converter housing and impeller set the fluid in motion.

- The turbine reacts to the fluid motion from the impeller, transferring rotation to the geartrain.
- The stator redirects fluid going back into the impeller, allowing for torque multiplication.

The addition of a torque converter clutch to the converter provides a mechanical link between the converter housing and the engine, allowing for direct transfer of power from the engine to the geartrain.

The converter clutch pressure plate is applied and released by fluid pressure, which is controlled by the EEC-IV microprocessor through an electronic solenoid in the valve body.

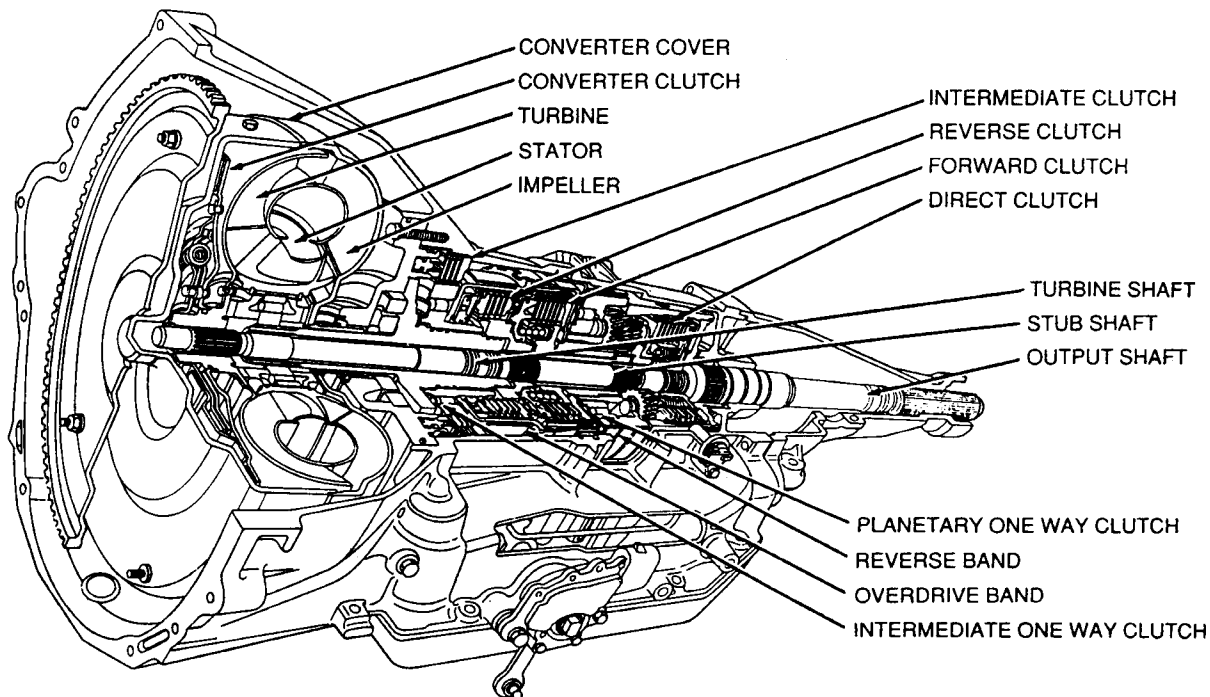



Technical Service Information

Geartrain

Power is transmitted from the torque converter to the Ravigneaux geartrain components through the input shaft and stub shaft. The geartrain contains a compound planetary set connected by dual pinion gears. By holding or driving certain members of the gearset, four forward ratios and one reverse ratio are obtained and transmitted to the output shaft. The ratios are as follows:

1st gear	2.40 to 1
2nd gear	1.47 to 1
3rd gear	1.00 to 1
4th gear	0.67 to 1
Reverse	2.00 to 1

Members of the gearset are held or driven by a series of bands or clutches. The AOD-E uses two bands, two one-way clutches and four friction clutches.

Main Geartrain Components

Turbine (Input) Shaft—The turbine (input) shaft transfers speed and torque from the converter turbine to the geartrain. This shaft is splined to the turbine on one end and to the forward sun gear and stub shaft on the other end.

Stub Shaft

The stub shaft transfers power from the turbine shaft to the planet carrier during third and fourth gear operation.

Compound Planetary Gearset

The planetary gearset in the AOD-E is a Ravigneaux-type set consisting of forward and reverse sun gears, a pinion carrier, long and short pinions and a ring gear. Members are driven or held to produce four forward gear ratios plus one reverse ratio.

Output Shaft

The output shaft provides torque to the propeller shaft and rear axle assembly. It is driven by the ring gear of the planetary gearset.

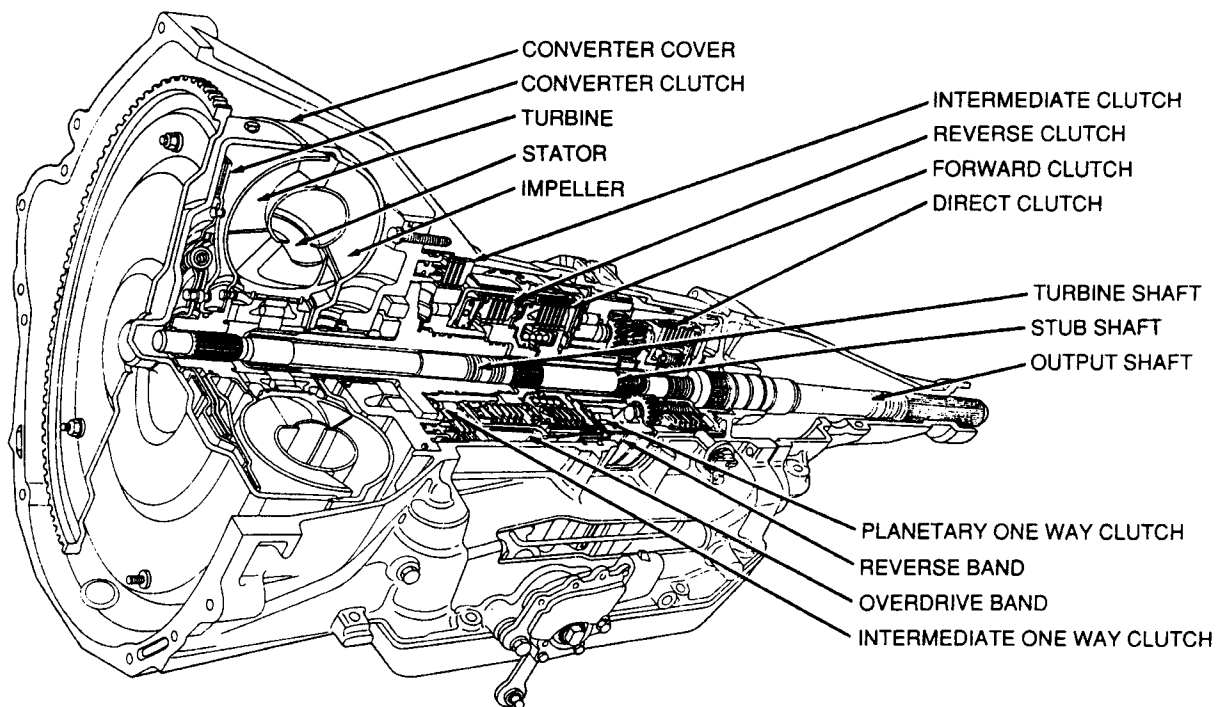

Electronics

Shift timing, shift feel (line pressure) and converter clutch control in the AOD-E are controlled electronically by the EEC-IV microprocessor and its input/output network. The transmission control is separate from the engine control strategy in the EEC-IV microprocessor, although some of the input signals are shared.

Some input signals come from engine-related sensors (mass air-flow sensor, engine coolant temperature sensor, barometric absolute pressure sensor, etc.) to give the EEC-IV microprocessor an idea of the load and climate the engine is operating under. Some other inputs are based on driver inputs, such as accelerator pedal position which is related to the microprocessor by the throttle position sensor. Still other inputs are provided by the transmission itself, from sensors such as the output speed sensor, the manual lever position sensor (controlled by driver placement of the shift lever) and the transmission oil temperature sensor.

Using all of these input signals, the EEC-IV microprocessor can determine when the time and conditions are right for a shift or converter clutch application. The microprocessor can also determine the line pressure needed to optimize shift feel. To accomplish these functions, the EEC-IV microprocessor controls four electronic solenoids—two On/Off solenoids for shifting, one pulse-width modulated (PWM) solenoid for converter clutch control or "controlled slip" of the converter clutch and an electronic pressure control (EPC) solenoid for line pressure control.

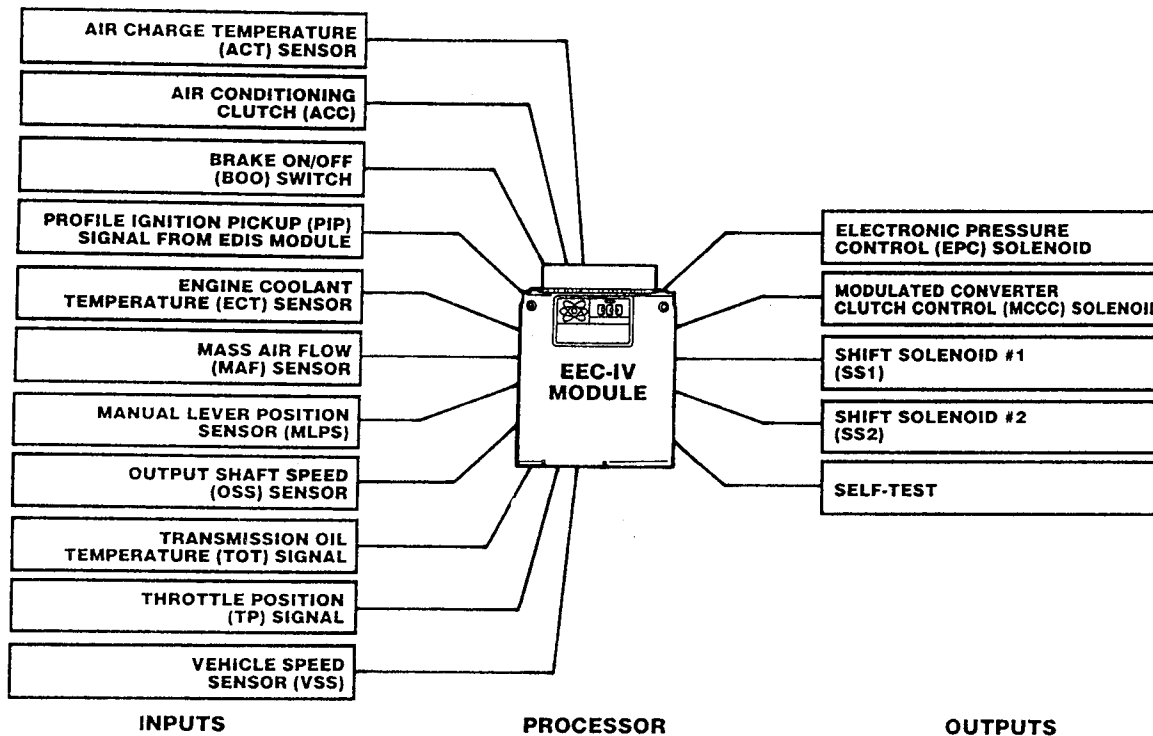

Engine and Driver Demands

The EEC-IV microprocessor receives and sends electrical signals that are used to make the AOD-E transmission more responsive to driver and vehicle needs.

The driver demands are transmitted to the EEC-IV microprocessor through three components:

- Shift selector lever—The driver's demand for a particular gear range is translated into an electrical signal for the EEC-IV microprocessor by the manual lever position sensor.

- Accelerator pedal—The driver's demand for torque and acceleration are sent mechanically to the throttle body on the engine. A throttle position sensor then translates this mechanical motion into an electrical signal and sends it to the EEC-IV microprocessor.
- Brake pedal—A brake On/Off switch is used to tell the processor when the brake is applied, indicating the driver demand to disengage the converter and possibly command a downshift.

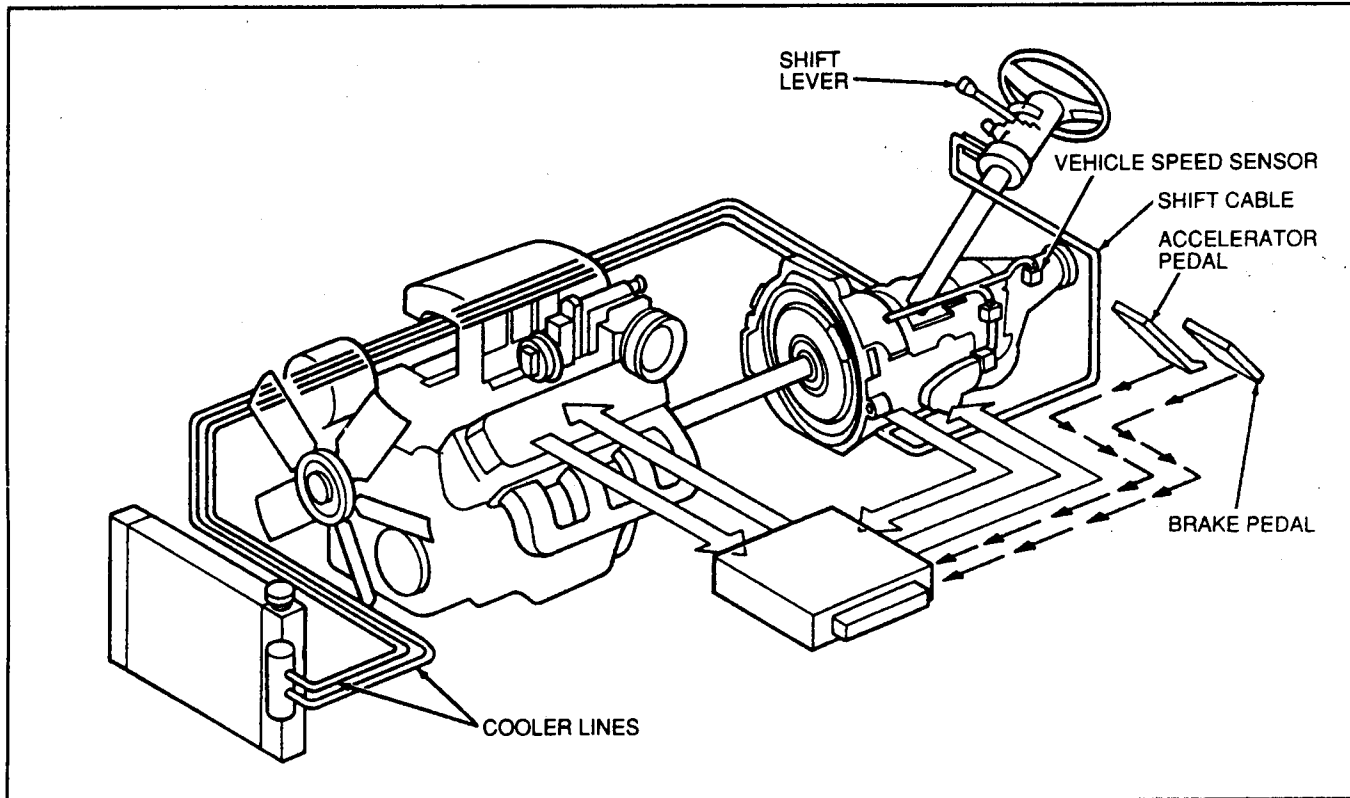

AOD-E Transmission Electronic Control System

The following is a list of the actuators and sensors used in controlling the transmission.

- Electronic Control Microprocessor Assembly (ECA)

INPUTS

- Engine Coolant Temperature (ECT) Sensor
- Air Charge Temperature (ACT) Sensor
- Transmission Operating Temperature (TOT) Sensor
- Manual Lever Position Sensor (MLPS)
- Brake ON/OFF (BOO) Switch
- Electronic Distributorless Ignition System (EDIS)

- Air Conditioning Clutch (ACC)
- Mass Air Flow (MAF) Sensor
- Throttle Position (TP) Sensor
- Output Shaft Speed (OSS) Sensor
- Vehicle Speed Sensor (VSS)

OUTPUTS

- Shift Solenoid Assembly
 - Shift Solenoid 1 (SS-1)
 - Shift Solenoid 2 (SS-2)
- Electronic Pressure Control (EPC) Solenoid
- Modulated Converter Clutch Control (MCCC)

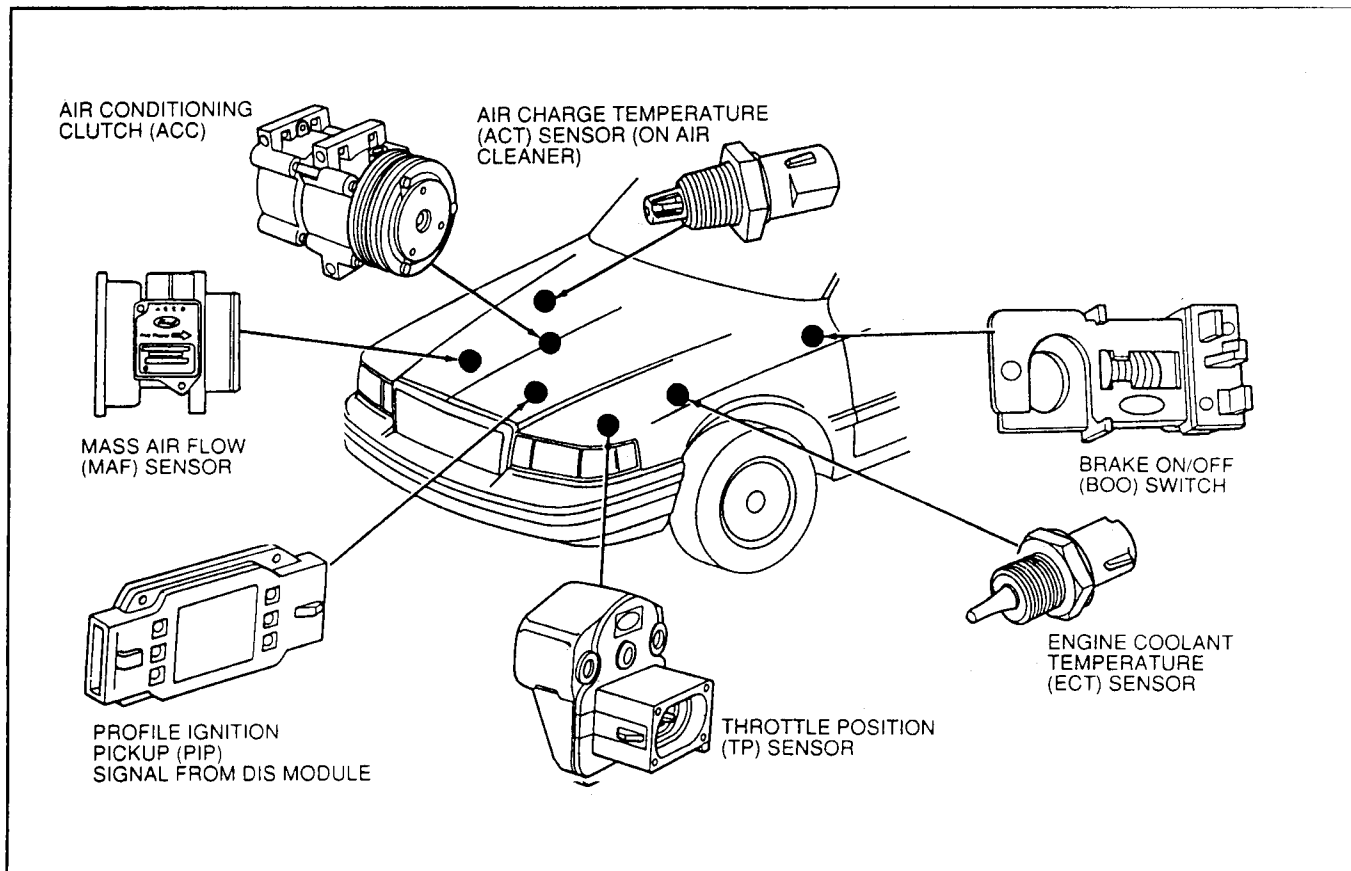

Electronic Control Assembly (ECA)

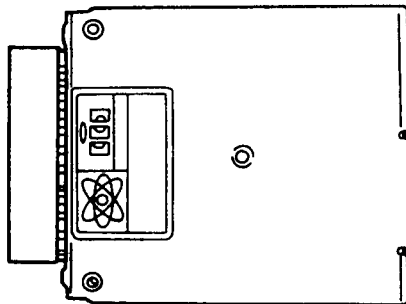

The operation of the AOD-E automatic transmission is controlled by the EEC-IV electronic control assembly (ECA) microprocessor. Many input sensors provide information to the microprocessor. The microprocessor then controls actuators which determine transmission operation.

Fault Codes: 511, 512 and 513

Engine Coolant Temperature (ECT) Sensor

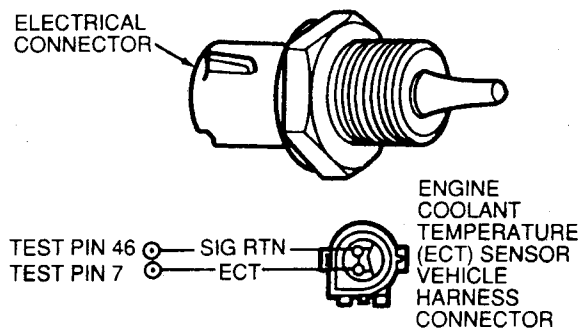

The engine coolant temperature (ECT) sensor detects temperature of engine coolant and supplies information to the EEC-IV microprocessor.

The ECT sensor is installed into the heater outlet fitting or cooling passage on the engine. For engine control applications, the ECT signal is used to modify ignition timing, EGR flow and air-to-fuel ratio as a function of engine coolant temperature. On electronic instrument clusters, the ECT output is used to control the coolant temperature indicator.

Transmission Function: ECT is used to control modulated converter clutch operation.

Symptoms: Modulated converter clutch will always be off, resulting in reduced fuel economy.

Fault Codes: 116, 117 and 118

Air Charge Temperature (ACT) Sensor

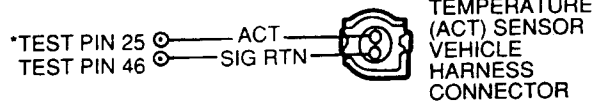
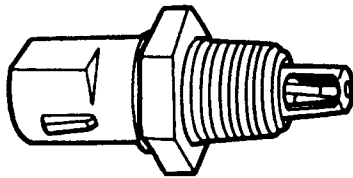

The sensor provides the electronic fuel injection (EFI) system with mixture (fuel and air) temperature information. The ACT is used both as a density corrector for airflow calculation and to proportion cold enrichment fuel flow.

The sensor is installed into a cylinder runner of the intake manifold or mounted in the air cleaner assembly and provides the fuel system with mixture temperature information. The sensor input is used as a density corrector for airflow calculations and to proportion cold enrichment fuel flow.

Transmission Function: ACT is used in determining EPC pressure.

Symptoms: Incorrect EPC pressure either high or low will result in either harsh or soft shifts.

Fault Codes: 114, 112 and 113

Transmission Operating Temperature (TOT) Sensor

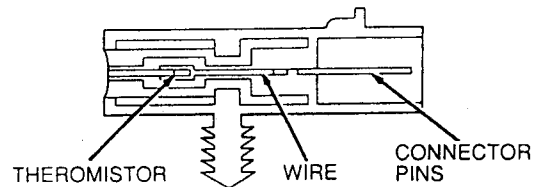
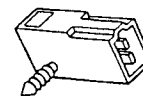
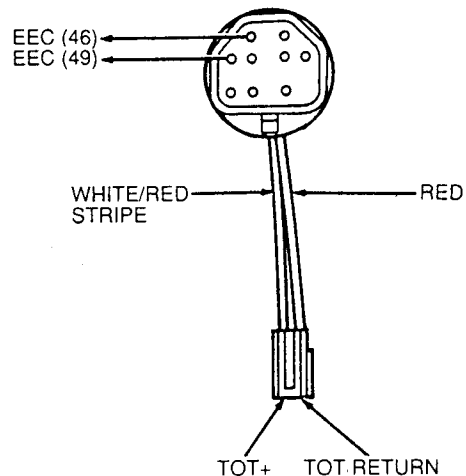

The transmission operating temperature (TOT) sensor is located on the transmission main control in the transmission sump. It is a temperature sensitive device called a thermistor. It sends a voltage signal to the microprocessor assembly. The voltage signal varies with transmission fluid temperature.

Transmission Function:

The microprocessor assembly uses this voltage signal to determine whether a cold start shift schedule is necessary. The shift schedule is compensated when the transmission fluid temperature is cold. The microprocessor also inhibits converter clutch operation at low transmission fluid temperatures and corrects EPC pressures for temperature.

Symptoms:

Converter clutch engagement and stabilized shift schedules happen too soon after a cold start.

Fault Codes: 636, 637 and 638

Manual Lever Position Sensor (MLPS)

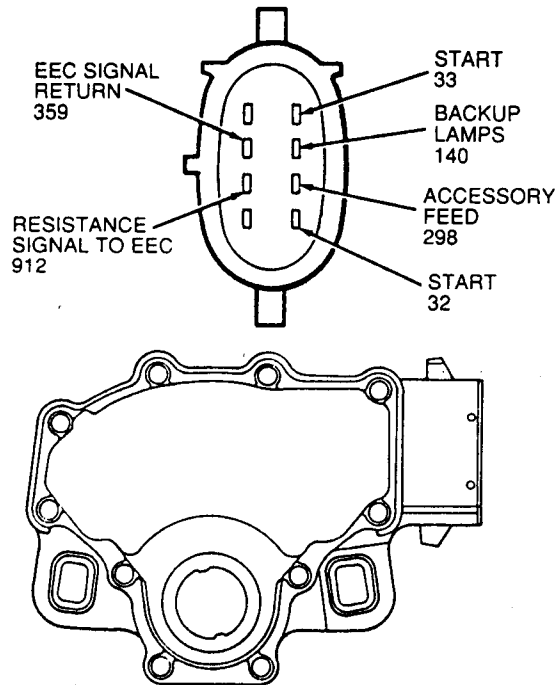

The manual lever position sensor (MLPS) sends a signal to the microprocessor assembly, which indicates position of the shift lever (P,R,N,⊙,D,1). The MLPS is located on the outside of the transmission on the manual lever shaft.

Transmission Function:

Determines desired gear and EPC pressure.

Symptoms:

Engagement concerns, wrong gear, no shifts.

Fault Codes: 634 and 522

NOTE: The sensor also contains the neutral / start and backup lamp circuits.

Brake ON/OFF (BOO) Switch

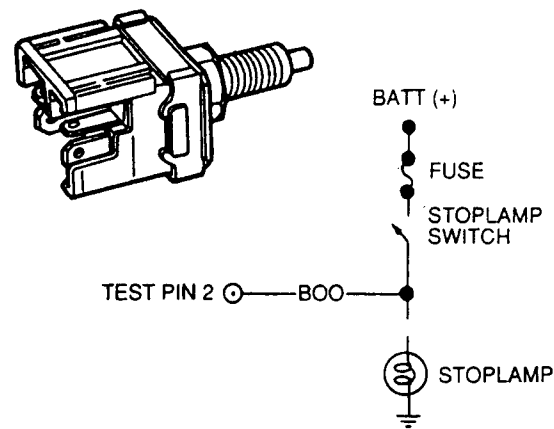

The brake ON/OFF (BOO) switch tells the microprocessor assembly when the brakes are applied. The switch closes when brakes are applied and opens when they are released.

Transmission Function:

Disengage converter clutch when brake is applied.

Symptoms:

Failed "ON"—converter clutch will not engage at less than one-third throttle.

Failed "OFF" or not connected—converter clutch will not disengage when brake is applied.

Fault Code: 536

Electronic Distributorless Ignition System (EDIS)

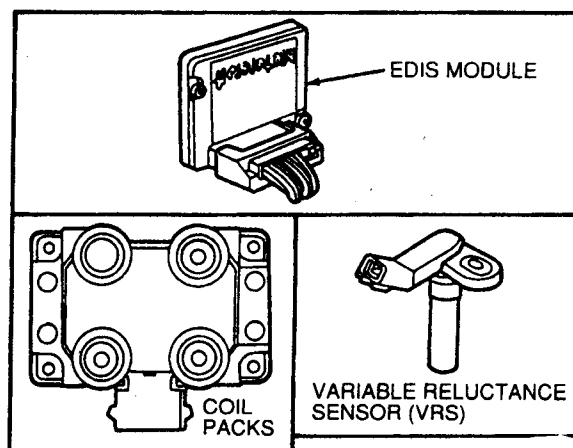

The electronic distributorless ignition system (EDIS) consists of a variable reluctance sensor (VRS), EDIS ignition module, two four tower coil packs and microprocessor assembly. The EDIS operates by sending crankshaft position information from the VRS to the EDIS module. The module generates a PIP signal (engine rpm) and sends it to the EEC-IV microprocessor.

Transmission Function:

Uses rpm signal in the transmission strategy. Wide-open throttle (WOT) shift control, converter clutch control and EPC pressure.

Symptoms:

Harsh engagements and shifts, late WOT shift, no converter clutch engagement.

Fault Codes: 211, 212, 214 through 217, 232, 238 and 241

Air Conditioning Clutch (ACC)

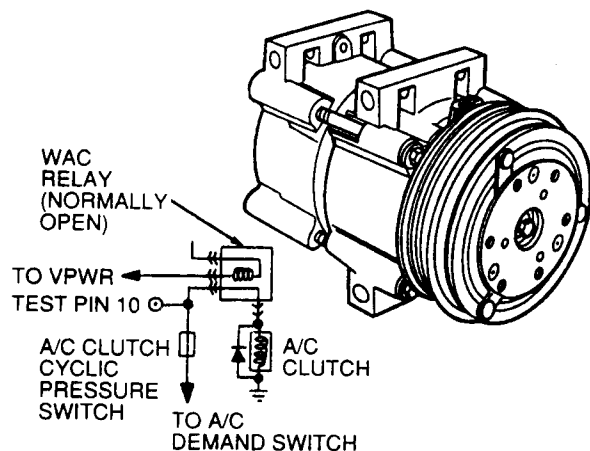

An electro-magnetic clutch is energized when the clutch cycling pressure switch closes. The switch is located on the suction accumulator-drier. The closing of the switch completes the circuit to the clutch and draws it into engagement with the compressor drive shaft.

Transmission Function:

Adjust EPC pressure when A/C compressor clutch is engaged to compensate for additional load on the engine.

Symptoms:

Failed "ON"—EPC pressure slightly low with A/C OFF.

Failed "OFF"—EPC pressure slightly high with A/C ON.

Fault Code: 539

Mass Air Flow (MAF) Sensor

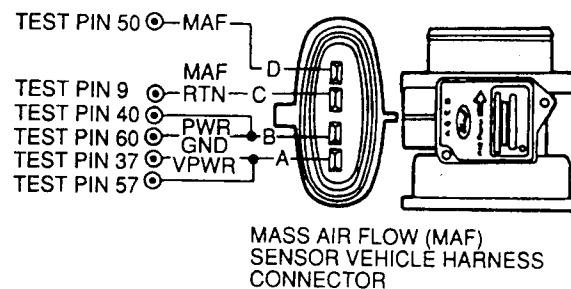

The mass air flow (MAF) sensor directly measures the mass of air flowing into the engine. The sensor output is a D.C. (analog) signal ranging from 0.5 volt to 5 volts used by the microprocessor to calculate injector pulse width. For transmission strategies this sensor is used for EPC pressure control, shift and converter clutch scheduling.

Transmission Function:

EPC pressure control, shift and converter clutch scheduling.

Symptoms:

High/low EPC pressure, incorrect shift schedule, incorrect converter engagement scheduling and symptoms similar to a throttle position (TP) sensor malfunction.

Fault Codes: 157, 158, 159, 184 and 185

Throttle Position (TP) Sensor

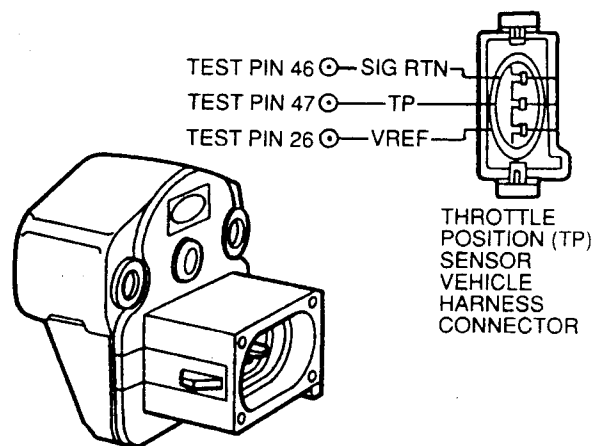

The throttle position (TP) sensor is a potentiometer mounted on the throttle body. The TP sensor detects the position of the throttle plate and sends this information to the microprocessor assembly as a varying voltage signal.

Transmission Function:

Shift scheduling, EPC pressure control, converter clutch control.

Symptoms:

Harsh engagements, firm shift feel, abnormal shift schedule, converter clutch does not engage, converter clutch cycling.

Fault Codes: 121, 122, 123, 124, 125 and 167

Output Shaft Speed (OSS) Sensor

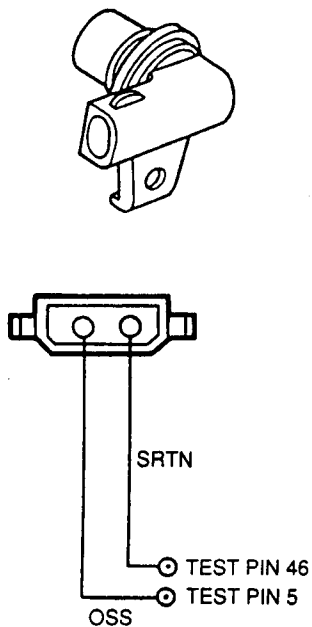

An output shaft speed (OSS) sensor is a magnetic pickup that sends a signal to the microprocessor assembly to indicate transmission output shaft speed.

Transmission Function:

Convert clutch control, shift scheduling, used in determining EPC pressure.

Symptoms:

No converter engagements, harsh shifts, abnormal shift schedules.

Fault Code: 639

Vehicle Speed Sensor (VSS)

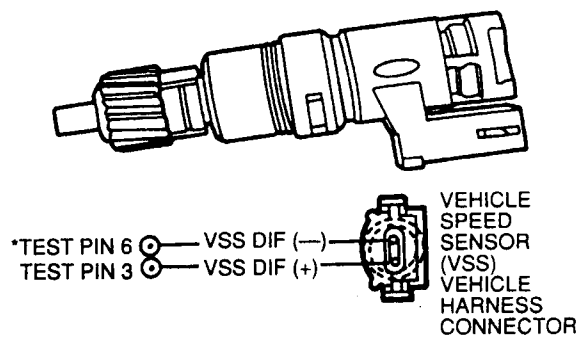

The vehicle speed sensor (VSS) is a magnetic pickup that sends a signal to the microprocessor assembly. This VSS signal tells the microprocessor assembly vehicle speed.

Transmission Function:

Modifies upshift schedules.

Symptoms: Shift busyness on grades.

Fault Code: 452

Shift Solenoid Assembly (SS-1 and SS-2)

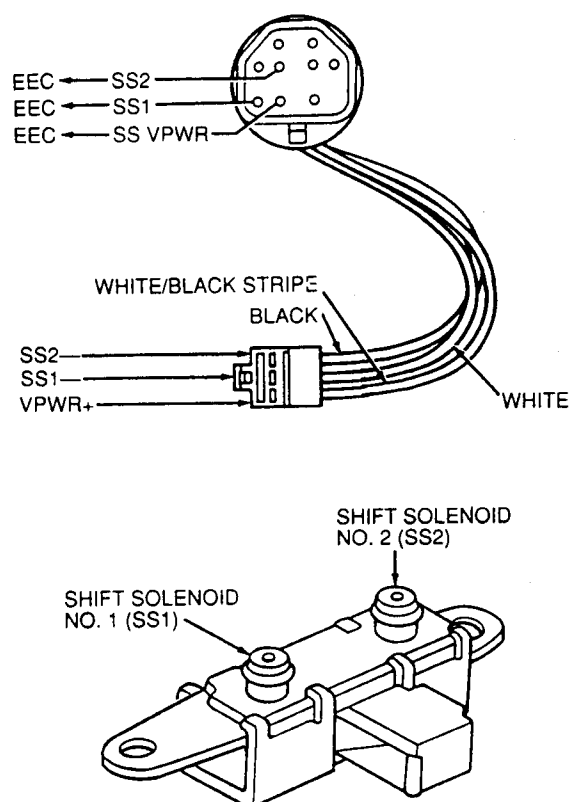

Two ON/OFF solenoids are used for electronic shift scheduling. One unit containing the two solenoids is located in the main control assembly. The solenoids are two-way, normally open style.

Transmission Function:

Solenoids SS-1 and SS-2 provide gear selection of first through fourth gears by controlling the pressure to the three shift valves.

SS-1 Symptoms:

Improper gear selection depending on failure mode and manual lever position.

Failed "ON"—first and fourth gear only.

Failed "OFF"—second and third gear only.

Fault Codes: 617**, 618**, 619** and 621*

SS-2 Symptoms:

Improper gear selection depending on failure mode and manual lever position.

Failed "ON"—third and fourth gear only.

Failed "OFF"—first and second gear only.

Fault Codes: 618**, 619** and 622*

SS-1 and SS-2 Symptoms:

Both failed "ON"—fourth gear only.

Both failed "OFF"—second gear only.

Fault Codes: 621* and 622*

* Output circuit check, generated only by electrical conditions.

** May also be generated by some non-electrical transmission component condition.

Modulated Converter Clutch Control (MCCC) Solenoid

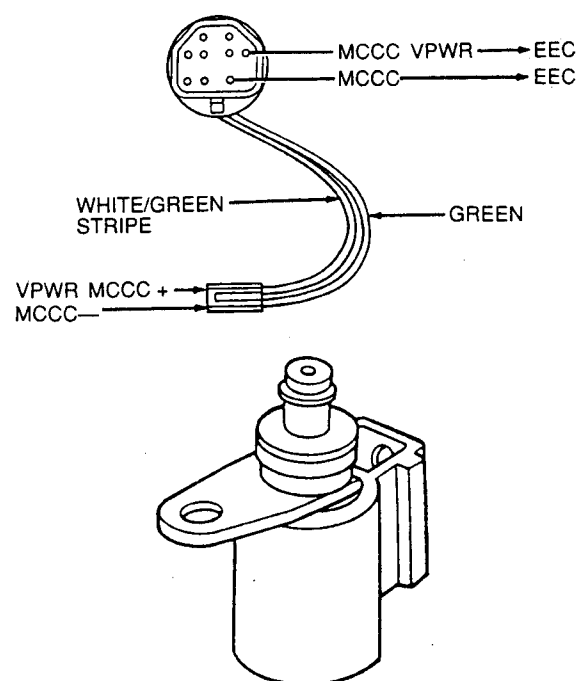

The modulated converter clutch control (MCCC) solenoid is used to control the apply and release of the torque converter clutch.

Transmission Function:

Used to engage the converter clutch.

Symptoms:

Failed "ON"—engine stalls in second gear (D, D range) at low idle speeds with the brake applied.

Failed "OFF"—converter never engages.

Fault Codes: 628** and 652*

* Output circuit check, generated only by electrical conditions.

** May also be generated by some non-electrical transmission component condition.



Technical Service Information

Electronic Pressure Control (EPC) Solenoid

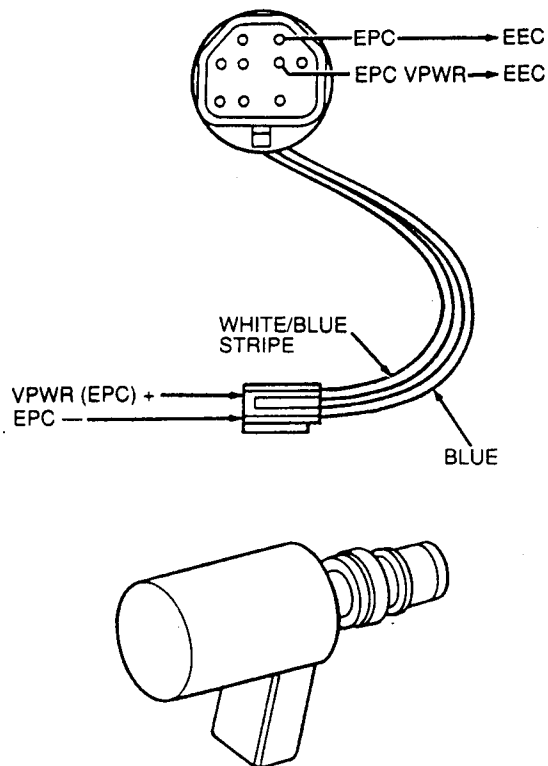

The electronic pressure control (EPC) solenoid regulates transmission EPC (TV) pressure. EPC valve pressure is used to control line pressure and the 2-3 backout valve function.

Actuator:

Electronic pressure control (EPC)

Transmission Function:

Regulates EPC pressure, 2-3 backout valve control, line pressure.

Symptoms:

Failed "ON"—Minimum EPC pressure (minimum capacity), limit engine torque (alternate firing).

Failed "OFF"—Maximum EPC pressure, harsh engagements, harsh shifts.

Fault Codes: 624 and 625

Shift Solenoid Failure Modes

Shift solenoid failure "always ON":

Failed "On" due to microprocessor assembly and/or vehicle wiring concerns, solenoid electrically or hydraulically stuck "ON".

SS-1 ALWAYS ON:	Gear Selector Position		
	OD	D	1
ECA Gear Commanded	Actual Gear Obtained		
1	1	1	1
2	1	1	1
3	4	3	1
4	4	3	1

SS-2 ALWAYS ON:	Gear Selector Position		
	OD	D	1
ECA Gear Commanded	Actual Gear Obtained		
1	4	3	1
2	3	3	1
3	3	3	1
4	4	4	1

Shift solenoid failure "always OFF":

Failed "OFF" due to microprocessor assembly and/or vehicle wiring concerns, solenoid electrically or hydraulically stuck "OFF".

SS-1 ALWAYS OFF:	Gear Selector Position		
	OD	D	1
ECA Gear Commanded	Actual Gear Obtained		
1	2	2	2
2	2	2	2
3	3	3	2
4	3	3	2

SS-2 ALWAYS OFF:	Gear Selector Position		
	OD	D	1
ECA Gear Commanded	Actual Gear Obtained		
1	1	1	1
2	2	2	1
3	2	2	1
4	1	1	1

AOD-E Solenoid Operations

Gear Selection	Gear	SS-1	SS-2	MCCC
Ⓢ	1	ON	OFF	HD
	2	OFF	OFF	EC
	3	OFF	ON	EC
	4	ON	ON	EC
D	1	ON	OFF	HD
	2	OFF	OFF	EC
	3	OFF	ON	EC
1	1	ON	OFF	HD
N	N	ON	OFF	HD
R	R	ON	OFF	HD
P	P	ON	OFF	HD

EC = Electronically Controlled
HD = Hydraulically Disabled

Transmission—AOD-E

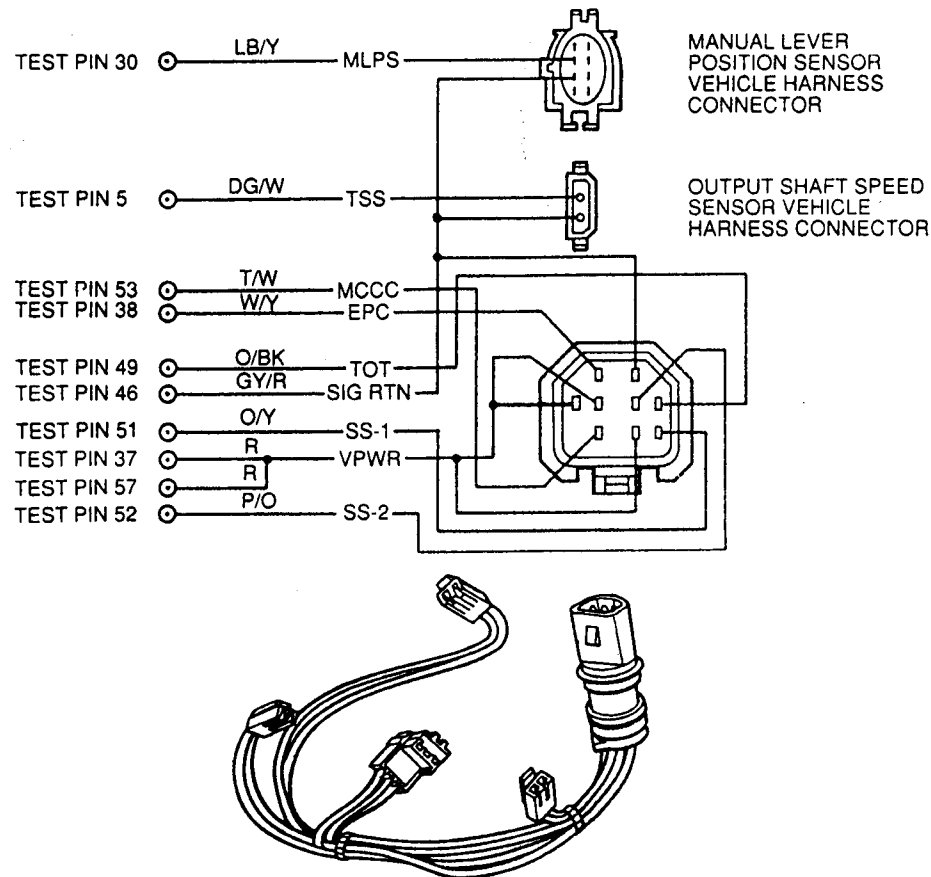

DIAGNOSIS AND TESTING

Troubleshooting the automatic transmission is simplified by using the proven method of diagnosis. One of the most important things to remember is that there is a definite procedure to follow. Do not take short cuts or assume that critical checks or adjustments have already been made.

The following procedures are recommended for checking and/or verifying that the various components are adjusted and operating properly. Use Rotunda Automatic Transmission Tester 014-00737 or equivalent. Follow the manufacturer's instructions.

Preliminary Inspection

The following items must be checked before proceeding:

- Check Fluid Level / Condition
- Vehicle at Normal Operating Temperature
- Visual Inspection of Harness Connections / Wiring

- **Was Self Test Run?**
- Check for Leaks
- Check for Electronic Add-On Items
- Check for Vehicle Modifications
- Check Shift Linkage for Proper Adjustment
- Validate Customer Concern (When does condition exist?)
 - Upshift
 - Downshift
 - Coasting
 - Engagement
 - Noise / Vibration
 - Determine if noise / vibration is related to the following:
 - RPM Dependent
 - Vehicle Speed Dependent
 - Shift Dependent
 - Gear Dependent

Transmission Fluid Level Check

CAUTION: Vehicle should not be driven if fluid level is below the bottom hole.

Transmission Hot—Operating Temperature

The automatic transmission should be checked at an operating temperature of 66°C-77°C (150°F-170°F) (dipstick hot to touch). The operating temperature may be obtained by driving 24-32 km (15-20 miles) of city-type driving with the outside temperature above 10°C (50°F).

Dipstick Reading: Fluid level at operating temperature.

Fluid level on dipstick should be within the cross-hatched area.

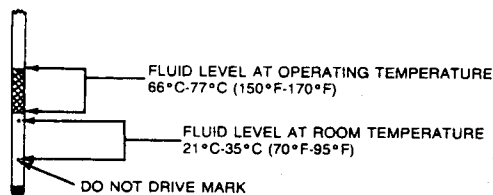

Transmission Cold—Room Temperature

If the transmission is not at an operating temperature of 66°C-77°C (150°F-170°F) and it becomes necessary to check the fluid level (such as pre-delivery), the fluid may be checked at room temperature of 21°C-35°C (70°F-95°F) (dipstick cool to touch).

Dipstick Reading: Fluid level at room temperature.

Fluid level on the dipstick should read between the holes at room temperature.

Check fluid level as follows:

1. With transmission in PARK, engine at curb idle rpm, foot brakes applied and vehicle on level surface, move the transmission selector lever through each range. Allow time in each range to engage transmission, return to PARK, apply parking brake and block wheels. **Do not turn off the engine during the fluid level check.**
2. Clean all dirt from the transmission fluid dipstick cap before removing the dipstick from the filler tube.
3. Pull the dipstick out of the tube, wipe it clean, and push all the way back into the tube. **Ensure it is fully seated.**

4. Pull the dipstick out of the tube again and check the fluid level.

NOTE: The fluid level indication on the dipstick will be different at operating temperature and room temperature. For the correct fluid level reading on the dipstick, follow the appropriate instructions stated previously.

Before adding fluid, ensure that the correct type will be used. Only use fluid that meets or exceeds the specification stamped on the dipstick.

CAUTION: If vehicle has been operated for an extended period at high speed, in city traffic, in hot weather, or vehicle is being used to pull a trailer, the fluid has to cool, approximately 30 minutes after engine has been turned off to obtain an accurate reading.

CAUTION: Use of a fluid other than specified could result in transmission malfunction and/or failure.

If necessary, add enough fluid through the filler tube to raise the level to the correct position. Do not overfill the transmission. This will result in foaming, loss of fluid through the vent and possible transmission malfunction. If overfill occurs, excess fluid must be removed.

5. Install the dipstick, making sure it is fully seated in the tube.

If the transmission fluid level is correctly established at 21°C-35°C (70°F-95°F), it will appear in the cross-hatch area on the dipstick when the transmission reaches an operating temperature of 66°C-77°C (150°F-170°F). Do not overfill or underfill.

Underfill can result in transmission loss of engagement or slipping. This condition is most evident in cold weather or when the vehicle is parked or being driven on a hill.

If the transmission fluid level is checked when the fluid is at room temperature, the dipstick could indicate that fluid should be added if the dipstick is misread. If fluid is added at this time, an overfill condition could result when the fluid reaches operating temperatures of 66°C-77°C (150°F-170°F) (dipstick hot to touch).

Transmission Fluid Condition Check

1. Make the normal fluid check as outlined.
2. Observe color and odor of the fluid. It should be dark reddish, not brown or black. Odor can sometimes indicate that there is an overheating condition or clutch disc or band failure.
3. Use an absorbent white facial tissue to wipe the dipstick. Examine the stain for evidence of solids (specks of any kind) and for antifreeze signs (gum or varnish on dipstick).



- a. Remove the transmission dipstick and note the color of the fluid. Original factory fill fluid is dyed red to aid in determining if leakage is from the engine or transmission. Unless a considerable amount of makeup fluid has been added or the fluid has been changed, the red color should assist in pinpointing the leak. However, a power steering leak may be mistaken for a transmission leak since the fluid color for both looks the same. Observe the power steering system for leaks that could be identified as a transmission leak.
- b. Remove the converter housing cover. Clean off any fluid from the top and bottom of the converter housing, front of the transmission case and rear face of the engine and engine oil pan. Clean the converter area by washing with a suitable non-flammable solvent and blow dry with compressed air.
- c. Wash out the converter housing, the front of the flywheel and the converter drain plugs. The converter housing may be washed out using cleaning solvent and a squirt-type oil can. Blow all washed areas dry with compressed air.
- d. Start and run the engine until the transmission reaches its normal operating temperature. Observe the back of the block and top of the converter housing for evidence of fluid leakage. Raise the vehicle on a hoist and run the engine at fast idle, then at engine idle, occasionally shifting to the DRIVE and REVERSE ranges to increase pressure within the transmission. Observe the front of the flywheel, back of the block (in as far as possible), and inside the converter housing and front of the transmission case. Run the engine until fluid leakage is evident and the probable source of leakage can be determined.

Converter Leakage Check

If welds on the torque converter indicate leakage remove the converter and make the following check:

Assemble Rotunda Torque Converter Leak Detector O21-00054 or equivalent to the converter. Test the converter for leaks, following the directions supplied with the detector kit.

Engine Idle Speed Check

Including Throttle Positioner Application

If the idle speed is too low, the engine will run rough. An idle speed that is too high will cause the vehicle to creep, have harsh engagements, and harsh closed throttle downshifts.

Check and, if necessary adjust the engine idle speed with the throttle positioner (if applicable) or the injection pump linkage adjustment. Refer to the Powertrain Control/Emissions Diagnosis Manual¹ for the appropriate procedure according to throttle positioner application.

Shift Linkage Check

This is a **CRITICAL** adjustment. Be sure the ⊕ detent in the transmission corresponds exactly with the STOP in the steering column or console. Hydraulic leakage at the manual valve can cause delay in engagements and/or slipping while operating if the linkage is not correctly adjusted.

NOTE: Check for a misadjustment in shift linkage. Do this by matching the detents in the shift lever with those in the transmission. If they match, the misadjustment is in the indicator. Do not adjust the shift linkage.

Direct Clutch Pressure Test

The direct clutch pressure test outlined below will diagnose a low-pressure condition or leakage in the direct clutch circuit. A difference of 103 kPa (15 psi) or more between direct clutch pressure and line pressure (read at the forward clutch pressure tap) will prevent a normal 3-4 shift.

1. Attach 0-2000 kPa (0-300 psi) pressure gauges to the forward clutch pressure tap and to the direct clutch pressure tap. Gauges must be accurate enough to distinguish a 103 kPa (15 psi) difference. (If this test is done in conjunction with a control pressure test, pressure gauges will be attached to all pressure taps.) Have sufficient flexible hose to read the gauges in the vehicle.

CAUTION: Pressure gauges affect the shift quality of the transmission. Care should be taken not to accelerate or decelerate rapidly. Possible transmission failure could result.

2. Drive the vehicle. When pressure is applied to the direct clutch, note the difference between the pressure read at forward clutch pressure tap and the direct clutch pressure.
3. If the difference in pressures is less than 103 kPa (15 psi), the direct clutch circuit is OK.
4. If the difference is greater than 103 kPa (15 psi), there could be a leak in the direct clutch pressure circuit. If the difference does not exceed 103 kPa (15 psi), the gauges on the line pressure and direct clutch pressure can be switched to confirm that gauge calibration difference is not the cause.

¹ Can be purchased as a separate item.



Technical Service Information

Stall Test

The stall test checks converter clutch operation and installation, the holding ability of the forward clutch, reverse clutch the low-reverse bands, the planetary one-way clutch, and engine performance.

Conduct this test with the engine coolant and transmission fluid at proper levels and at operating temperature and with the TV linkage set properly.

Apply the service and parking brakes firmly for each stall test.

1. Find the specified stall rpm for the vehicle by referring to the Special Specifications booklet. Use a grease pencil to mark the rpm on the dial of a tachometer.
2. Connect tachometer to engine.

3. In each of the following ranges: Ⓢ, D, 1, R, press the accelerator to the floor and hold it just long enough to let the engine get to full rpm. While making this test, do not hold the throttle open for more than five seconds at a time.

NOTE: If the engine speed recorded by the tachometer exceeds the maximum limits given in the Special Specifications booklet, release the accelerator immediately because clutch or band slippage is indicated.

4. Note the results in each range.
5. After each range, move the selector lever to NEUTRAL and run the engine at 1000 rpm for about 15 seconds to cool the converter before making the next test.
6. Refer to the following chart for corrective actions.

Selector Position	Stall Speeds High	Stall Speeds Low
Ⓢ and D	Planetary One-Way Clutch	
Ⓢ, D and 1	Forward Clutch	
Ⓢ, D, 1 and R	General Problems Pressure Test	Converter Stator One-Way Clutch or Engine Performance
R	Reverse Clutch or Low Reverse Band or Servo	

Transmission Fluid Cooler Flow Check

The linkage, fluid and control pressure must be within specifications before performing this flow check.

Remove the transmission dipstick from the filler tube. Place a funnel in the transmission filler tube. Raise the vehicle and remove the cooler return line from its fitting in the case. Attach a hose to the cooler return line and fasten the free end of the hose in the funnel installed in the filler tube.

Start the engine and set idle speed at 1000 rpm with the transmission in NEUTRAL.

Observe the fluid flow at the funnel. When the flow is solid (air bleeding has been completed), the flow should be liberal. If there is not a liberal flow at 1000 rpm in NEUTRAL, low pump capacity, main circuit system leakage, or cooler system restriction is indicated.

Check both metal cooler lines between the transmission and radiator for restrictions. Check for restrictions in the metal or rubber cooler lines to and from the auxiliary cooler, if so equipped. Visually check and physically feel all bends for kinks, especially rubber cooler lines, that would restrict flow and could result in transmission overheating or lack of lubrication.

To separate transmission trouble from cooler system trouble, observe the flow at the transmission case converter-out fitting.

Reverse Clutch

Apply air pressure to the reverse clutch passage in the service tool. A dull thud can be heard when the clutch piston applies. In addition, movement of the reverse clutch drum may also be detected.

Forward Clutch

Apply air pressure to the forward clutch apply passage in the service tool plate. A dull thud can be heard or movement of the piston can be felt on the case as the clutch piston is applied.

Intermediate Clutch

Apply air pressure to the intermediate clutch passage in the service tool plate. A dull thud can be heard or felt when the clutch applies.



Technical Service Information

EEC-IV SELF TEST FAULT CODE DESCRIPTION CHART

FAULT CODE	COMPONENT	DESCRIPTION	CONDITION	SYMPTOMS/ACTIONS
THREE DIGIT				
111	SYSTEM	Pass	No fault detected.	Fault not detected by microprocessor. ①
452	VSS	Insufficient input from VSS	Microprocessor detected a loss of vehicle speed signal during operation.	Converter clutch engages, shift busyness on grades. ③
636	TOT	TOT out of S-T range	Transmission not at operating temperature during self test.	Warm vehicle to normal operating temperature.
637	TOT	-40°C (-40°F) indicated TOT sensor circuit open	Voltage drop across TOT sensor exceeds scale set for temperature -40°C (-40°F).	Firm shift feel. Refer to Pinpoint Test B.
638	TOT	157°C (315°F) indicate TOT sensor circuit grounded	Voltage drop across TOT sensor exceeds scale set for temperature of 157°C (315°F).	
522	MLPS	MLPS not in PARK	Self test not run in PARK.	Rerun self test in PARK.
634	MLPS	MLPS out of range	Indicated voltage drop across MLPS exceeds limits established for each position. Misadjusted sensor.	Harsh engagements, firm shift feel, no crank in neutral, improper shifts. Refer to Pinpoint Test D.
536	BOO	Brake not actuated during self test	Brake not cycled during KOER.	Code set during self test. Rerun and depress BOO switch. ①
		BOO switch circuit failed	Brake On/Off circuit failure.	Failed ON — Converter clutch will not engage at less than 1/3 throttle. Failed OFF or not connected Converter clutch will not disengage when brake is applied. ①
112	ACT	ACT indicates 125°C (254°F)	Voltage drop across ACT exceeds scale set for temperature 125°C (254°F) (grounded).	Incorrect EPC pressure. Either high or low which will result in harsh or soft shifts. ①
113	ACT	ACT indicates -40°C (-40°F)	Voltage drop across ACT exceeds scale set for temperature -40°C (-40°F) (open circuit)	
114	ACT	ACT out of self test range	ACT temperature higher or lower than expected during KOEO, KOER.	Rerun self test with vehicle at normal operating temperature. ①
116	ECT	ECT out of self test range	ECT temperature higher or lower than expected during KOEO, KOER.	Rerun self test with vehicle at normal operating temperature. ①
117	ECT	ECT indicates 125°C (254°F)	Voltage drop across ECT exceeds scale set for temperature 125°C (254°F) (grounded).	Modulated Converter clutch will always be off resulting in reduced fuel economy. ①
118	ECT	ECT indicates -40°C (-40°F)	Voltage drop across ECT exceeds scale set for temperature -40°C (-40°F) (open circuit).	
639	OSS	Insufficient input from output shaft speed OSS sensor	Microprocessor detected a loss of OSS signal during operation.	Harsh shifts, abnormal shift schedule, no converter clutch activation. Refer to Pinpoint Test F.
121	TPS	TPS voltage high/low for self test	TPS was not in the correct position for self test.	Rerun at appropriate TP position.

① Refer to Powertrain Control/Emissions Diagnosis Manual. Can be purchased as a separate item.



Technical Service Information

EEC-IV SELF TEST FAULT CODE DESCRIPTION CHART (Continued)

FAULT CODE	COMPONENT	DESCRIPTION	CONDITION	SYMPTOMS/ACTIONS
THREE DIGIT				
122 123 124 125 167	TPS	TPS fault codes	Microprocessor assembly has detected an error. This error may cause a transmission concern.	Harsh engagements, firm shift feel, abnormal shift schedule, converter clutch does not engage, converter clutch cycling. ①
212 211-219 221-224 232-239 241-243	EDIS EDIS EDIS EDIS	EDIS fault codes	EDIS system has a malfunction which may cause a transmission concern.	Harsh engagements and shifts, late WOT shifts, no converter clutch engagement. ①
539	ACC	A/C switch error	A/C or defrost ON condition may result from A/C clutch being "on" during quick test. A/C clutch failed "on".	Code set during self test — Rerun test with A/C off. Failed ON — EPC pressure slightly low with A/C OFF. ①
157 184 158 185 159	MAF MAF MAF	MAF faults codes	MAF system has a malfunction which may cause a transmission concern.	High/low EPC pressure, incorrect shift schedule. Incorrect converter clutch scheduling, Symptoms similar to a TPS failure. ①
621 ②	SS-1	SS-1 solenoid circuit failure	SS-1 circuit failed to provide voltage drop across solenoid. Circuit open or shorted or microprocessor driver failure during self test.	Improper gear selection depending on failure mode and manual lever position. Refer to Solenoid On/Off Chart. Refer to Pinpoint Test A.
617 ③	SS-1 or internal parts	1-2 shift error	Engine rpm drop not detected when 1-2 shift was commanded by ECA.	Improper gear selection depending on failure or mode and manual lever position: Refer to Solenoid On/Off Chart. Shift errors may also be due to other internal transmission concerns. (Stuck valves, damaged friction material.) Refer to Pinpoint Test A.
618 ③	SS-1, SS-2 or internal parts	2-3 shift error	Engine rpm drop not detected when 2-3 shift was commanded by ECA.	
619 ③	SS-1, SS-2 or internal parts	3-4 shift error	Engine rpm drop not detected when 3-4 shift was commanded by ECA.	
622 ②	SS-2	SS-2 solenoid circuit failure	SS-2 circuit failed to provide voltage drop across solenoid. Circuit open or shorted or microprocessor driver failure during self test.	Improper gear selection depending on failure or mode and manual lever position. Refer to Solenoid On/Off Chart. Refer to Pinpoint Test A.
652 ②	MCCC	MCCC solenoid circuit failure during self test	MCCC solenoid circuit failed to provide drop across solenoid. Circuit open or shorted or microprocessor driver failure during self test.	Short circuit — engine stalls in second gear (OD, D range) at low idle speeds with brake applied. Open circuit — converter clutch never engaged. Refer to Pinpoint Test C.

① Refer to Powertrain Control/Emissions Diagnosis Manual. Can be purchased as a separate item.

② Output circuit check, generated only by electrical conditions.

③ May also be generated by other non-electrical related transmission hardware condition.

EEC-IV SELF TEST FAULT CODE DESCRIPTION CHART (Continued)

FAULT CODE THREE DIGIT	COMPONENT	DESCRIPTION	CONDITION	SYMPTOMS/ACTIONS
628 ^③	MCCC	Modulated converter clutch control engagement error	The microprocessor assembly picked up an excessive amount of converter clutch slippage when converter was scheduled to be engaged during normal vehicle operation.	Erratic or no converter clutch operation. Refer to Pinpoint Test C.
998 ^②		Failure mode effect management (FMEM) failure	Failure detected in one or more critical inputs.	ECA enables alternate functions. Check for other error codes.
624 ^②	EPC	EPC solenoid circuit failure, shorted circuit or output driver.	Voltage through EPC solenoid is checked. An error will be noted if tolerance is exceeded.	Short circuit causes minimum EPC pressure (minimum capacity) and limits engine torque (alternate firm).
625 ^②	EPC	Shorted ECA output driver.		Open circuit — causes maximum EPC pressure, harsh engagements and shifts. Refer to Pinpoint Test E.

① Refer to Powertrain Control/Emissions Diagnosis Manual. Can be purchased as a separate item.

② Output circuit check, generated only by electrical conditions.

③ May also be generated by other non-electrical related transmission hardware condition.

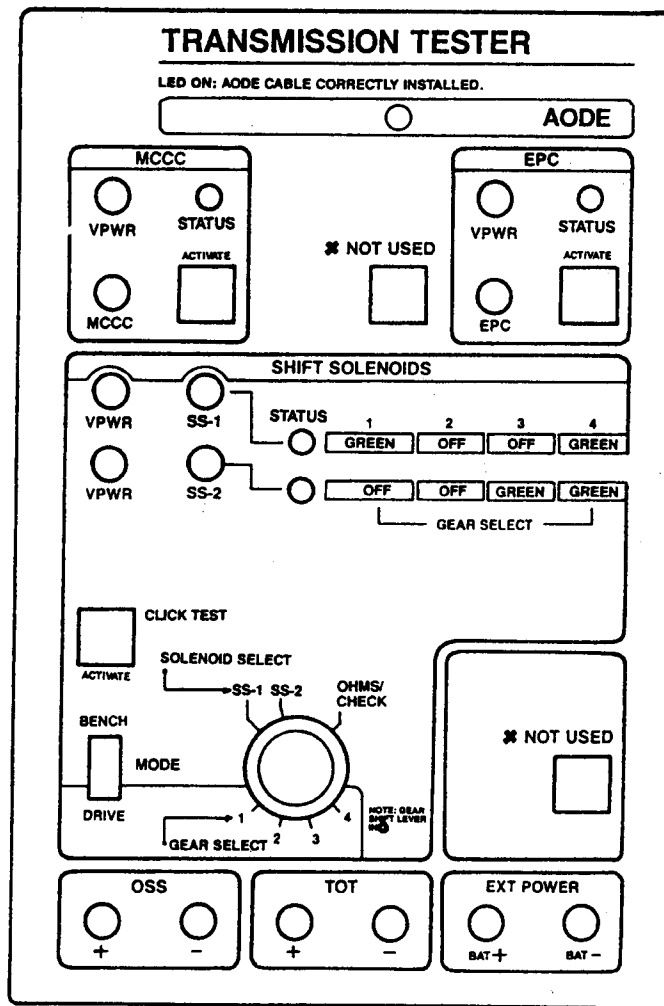

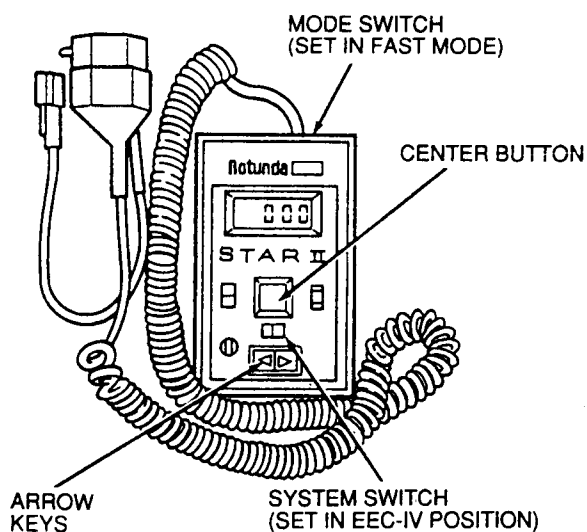

Transmission Tester Instructions

The Rotunda Transmission Tester 007-00085 or equivalent allows a technician to operate the electrical portion of the transmission independent of the vehicle electronics which allows the technician to determine transmission concerns. The Transmission Tester usage is divided in five steps:

- I. Preliminary Testing and Diagnosis
- II. Installing the Transmission Tester
- III. Static Testing - Vehicle OFF
- IV. Dynamic Testing - Vehicle Running
- V. Removing Transmission Tester and Clearing Fault Codes

I. Preliminary Testing and Diagnosis

Before any diagnostic testing is done on vehicle some preliminary checks must be performed, as outlined below. Be sure to write down findings, especially any fault codes found, for future reference.

- a. Check transmission fluid level and condition.
- b. Check for add-on items (phones, computers, CB radio, etc.).
- c. Visually inspect wiring harness and connectors.
- d. Check for vehicle modifications.
- e. Check shift linkage for proper adjustment.
- f. Verify customer concern:
 - Upshift, Downshift, Coasting, Engagement, Noise/Vibration
- g. Vehicle must be at normal operating temperature.
- h. Perform vehicle Self Test.
- i. Record all fault codes.
- j. Service all non-transmission codes.

II. Installing the Transmission Tester (Set-Up Procedures)

Installing the transmission tester at the transmission connector allows separation of the vehicle electronics from transmission electronics. Disconnecting normal vehicle electronics will set additional codes and cause firm shifts. (Disconnecting the transmission connector defaults transmission to maximum line pressure).

NOTE: During tester usage additional fault codes may be set. Therefore, it is important that all codes are erased after service has been made. To verify elimination of all codes rerun Self Test.

NOTE: The following manuals should be available to assist in diagnosis of electronically controlled transmissions:

- Powertrain Control/Emissions Diagnosis Manual⁴
- Transmission Tester Manual (provided with tester).

1. Disconnect vehicle wiring harness at transmission connector.

CAUTION: Do not attempt to pry off connectors with a screwdriver. This will damage the connector and could result in transmission concerns.

2. Turn tester solenoid select switch to the OHMS/CHECK position.
3. Connect appropriate tester interface cable and overlay to transmission and tester.

CAUTION: Route all cables away from heat sources.

4. Install a line pressure gauge into line pressure tap on transmission.

CAUTION: Route gauge line away from heat sources.

5. Plug transmission tester power supply into lighter receptacle. At this time, all LED's should illuminate for a short period and then turn off. This is the tester internal circuit check.
6. Position Bench/Drive switch to BENCH mode.

III. Static Testing - Vehicle Off

Static testing procedures allow for shop testing of the transmission in the vehicle or on the bench. Completion of these tests prove out transmission electronics.

CAUTION: For resistance checks, be sure the tester solenoid select switch is set to the OHMS/CHECK position or damage to the ohmmeter may result.

Resistance/Continuity Tests

- Refer to the appropriate Pinpoint Test to be performed based on the Self Test fault codes displayed.
- Using a Rotunda Digital Volt-Ohmmeter and the Transmission Tester perform the Pinpoint Tests as indicated based on the Self Test fault codes which were displayed.



- Service as indicated by the pinpoint tests. Always retest and road test vehicle after service.

Transmission Solenoids and Sensors Resistance Tests

EPC Solenoid

- Connect negative lead of ohmmeter to the EPC jack.
- Connect positive lead of ohmmeter to the VPWR jack.
- Set ohmmeter to 100-200 ohm range.
- Record resistance.
- Refer to the following charts for values.

If out of specification, refer to Pinpoint Test E in this Section.

Solenoids (SS-1, SS-2, MCCC)

- Connect positive lead of ohmmeter to the appropriate VPWR jack for the solenoid being tested.
- Set ohmmeter to 100-200 ohm range.
- Connect negative lead of the ohmmeter to the appropriate solenoid (SS-1, SS-2, MCCC) jack and record resistance.

Refer to following charts for values.

If out of specification, refer to Pinpoint Test A (SS-1, SS-2); Pinpoint Test C (MCCC);

TRANSMISSION APPLICATION

Solenoid	AOD-E
SS-1	20-30
SS-2	20-30
MCCC	1.0-3.0
EPC	2.48-5.66

Transmission Operating Temperature (TOT)

- Connect ohmmeter positive lead to +TOT jack.
- Connect ohmmeter negative lead to -TOT jack.
- Set ohmmeter to 1000 ohm scale.
- Record resistance. Resistance will vary with temperature.
- Refer to the following chart.

If out of specification, refer to Pinpoint Test B in this Section.

Temperature		Resistance
°C	°F	Ohms (K)
0-20	32-68	100K-37K
21-40	69-104	37K-16K
41-70	105-158	16K-5K
71-90	159-194	5K-2.7K
91-110	195-230	2.7K-1.5K
110-130	230-266	1.5K-0.8K

Output Shaft Speed (OSS) - AOD-E

Connect the positive lead of the ohmmeter to the +OSS.

Connect the negative lead of the ohmmeter to the -OSS.

Set ohmmeter to 1000 ohm (K) range.

Record resistance.

OSS should be 450-750 ohms.

If out of specification, refer to Pinpoint Test F in this Section.

Sensors Short To Ground and Solenoid Voltage Test

NOTE: LED will turn "green" when solenoid activates and turn OFF when deactivated.

LED will turn "red" if an **activated** solenoid/harness is shorted to BAT+.

LED will remain OFF if an **activated** solenoid/harness is shorted to ground or no continuity.

1. Set tester Bench/Drive switch to BENCH mode.
2. Set voltmeter to 20 volt DC range.
3. Connect voltmeter positive lead to the appropriate solenoid. Connect voltmeter negative lead to the appropriate solenoid.
4. Using a VOM, check for voltage across each solenoid by activating the solenoid switches. Depress the appropriate switch. The LED should illuminate, the voltage should change and an audible click may be heard. If LED does not illuminate, a short to ground condition exists.

NOTE: MCCC solenoid click may or may not be audible.

5. Observe and record values.

IV. Dynamic Testing - Vehicle Running

Dynamic testing is the final step in the transmission tester usage. It allows the transmission to be proven out electronically and hydraulically.

Transmission Solenoid Cycling and Drive Test Procedures

Preliminary Set Up

1. Set Bench/Drive switch to BENCH mode.
2. Place vehicle in PARK.
3. Start vehicle.

EPC Solenoid

CAUTION: Do not attempt to hold the EPC switch depressed (minimum line pressure) and stall the transmission (holding the vehicle with the brake while depressing the throttle with the transmission in gear), transmission damage will result.



Technical Service Information

4. Observe line pressure. Record value. Line pressure should go to maximum. If not, refer to the Hydraulic / Mechanical charts for diagnostic tips or Pinpoint Test E concerning EPC solenoid.
5. Depress EPC switch. Line pressure should drop to a minimum value. Record value. If not, refer to the Hydraulic / Mechanical diagnostic charts or Pinpoint Test E for the EPC solenoid.

Engagements

6. Set Bench / Drive switch to DRIVE mode.
7. Rotate gear select switch to first gear position.
8. Depress EPC switch. Line pressure should drop to idle pressure. While holding EPC switch down, shift vehicle from PARK to REVERSE.
Does vehicle shift into REVERSE?
Shift vehicle from REVERSE to DRIVE.
Does vehicle shift into DRIVE?

Release the EPC switch, pressure should return to maximum. Repeat engagements. With the EPC switch released, engagements should be firm.

Upshift / Downshift

NOTE: Upshifts and Downshifts will be firm during this procedure. Pressure gauges may be removed. These tests should be performed on the road. If performed on the hoist, feel at all shifts when they are engaged may not be possible.

LED's will turn "green" when solenoids are activated and turn OFF when deactivated. Refer to the appropriate overlay for the proper status shift sequence of the shift solenoids during upshifts and downshifts.

9. Shift vehicle into OVERDRIVE and accelerate to 24 km/h (15 mph), select second gear by rotating gear selector to second.
Did vehicle upshift to second gear?
Did appropriate shift solenoids activate / deactivate?
10. Accelerate to 40 km/h (25 mph) and select third gear.
Did vehicle upshift to third gear?
Did appropriate shift solenoids activate / deactivate?
11. Accelerate to 56-72 km/h (35 / 45 mph) and select fourth gear.
Did vehicle upshift to fourth gear?
Did appropriate shift solenoids activate / deactivate?
12. Reverse the order to Downshift.

Does vehicle downshift from fourth to third, third to second, and second to first?

Did appropriate shift solenoids activate / deactivate?

Converter Engagement

NOTE: This test should be performed on the road. If performed on a hoist, feeling the converter clutch engage may not be possible.

CAUTION: Do not depress MCCC/CCC switch with transmission in gear and the vehicle at a stop. Damage to converter clutch may result.

13. Accelerate and shift vehicle up into third gear. Hold speed steady and depress the MCCC / CCC switch.
Does the converter engage?
Does the engine rpm drop?
Did MCCC solenoid activate?

Output Shaft Speed Sensor Function Check

NOTE: This test may be performed on the hoist or on the road.

14. Set voltmeter to 20 volts AC.
Connect voltmeter positive lead to the (+) OSS jack.
Connect voltmeter negative lead to the (-) OSS jack.
Slowly accelerate vehicle and monitor voltmeter.
Does voltage increase with vehicle speed?

V. Removing Transmission Tester and Clearing Fault Codes

1. Disconnect transmission tester from transmission connector.
CAUTION: Do not attempt to pry off connectors with a screwdriver. This will damage the connector and could result in a transmission concern.
2. Re-install vehicle wiring harnesses. Verify connection by pulling up on the harness.
3. Re-install all heat shields that were previously removed.
4. Disconnect transmission tester power lead from vehicle.
5. Erase all fault codes using the procedures in the Powertrain Control / Emissions Diagnosis Manual.⁵
6. Rerun EEC-IV Self Test to receive a pass code (111).
7. Verify customer concern has been eliminated.

5 Can be purchased as a separate item.

AOD-E INTERNAL HARNESS

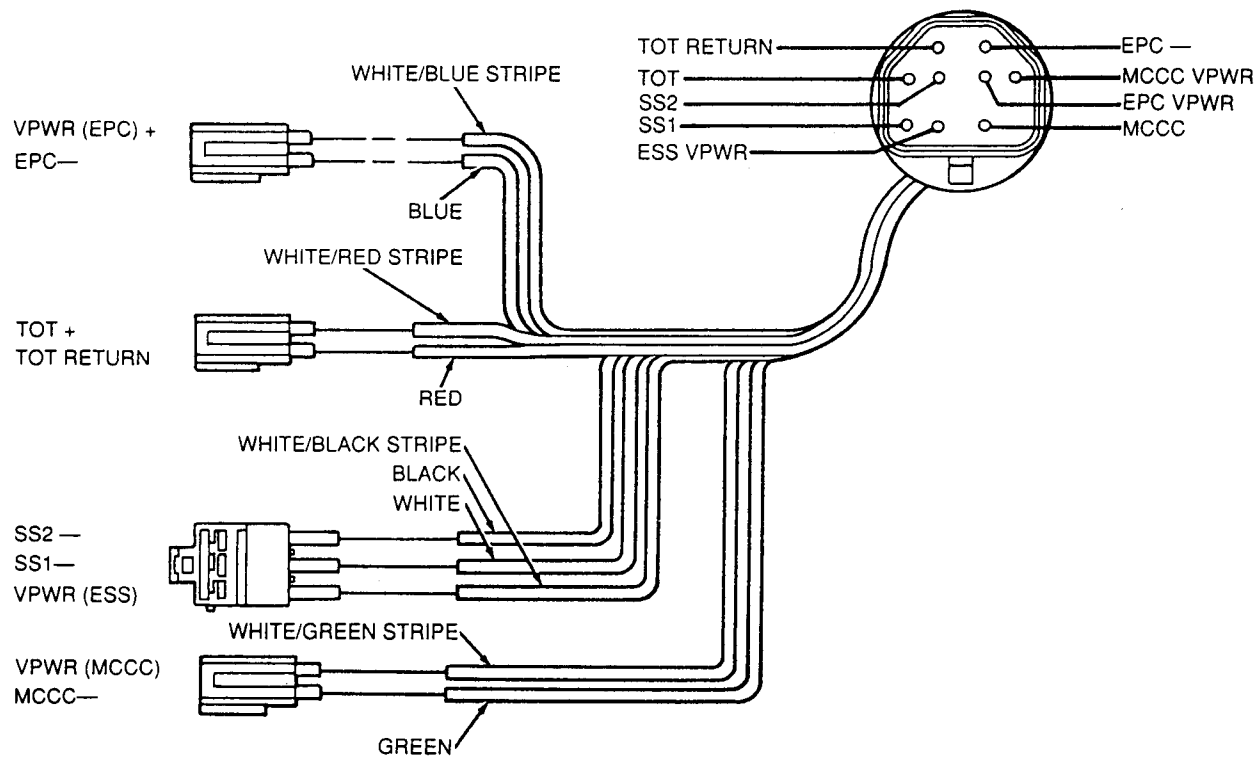

PINPOINT TEST A: FAULT CODES: 617, 618, 619, 621, 622

TEST STEP	RESULT	ACTION TO TAKE
A1 AOD-E ELECTRONIC DIAGNOSTICS <ul style="list-style-type: none"> ● The following items must be checked before proceeding: <ul style="list-style-type: none"> — Check the EEC-IV microprocessor assembly for proper function (Self Test). — Check vehicle wiring harness for continuity and shorts to ground. — Make sure all connectors are engaged properly. — Make sure all terminals in connectors are properly seated. — Check all connectors for damage, corrosion, water, bent pins and missing or damaged seals. ● Have items been checked? 	Yes No	► GO to A2 . ► PERFORM checks.
A2 CHECK HARNESS CONNECTIONS <ul style="list-style-type: none"> ● Check that vehicle harness connector is fully engaged on bulkhead connector. ● Check that vehicle harness connector terminals are fully engaged in connector. ● Are terminals fully engaged? 	Yes No	► GO to A3 . ► SERVICE as required.



Technical Service Information

PINPOINT TEST A: FAULT CODES: 617, 618, 619, 621, 622 (Continued)

TEST STEP		RESULT	ACTION TO TAKE
A3	TRANSMISSION FUNCTIONAL TEST		
	<ul style="list-style-type: none"> ● Disconnect vehicle harness at transmission. ● Install Transmission Tester 007-00085 or equivalent to transmission connector. ● Using tests outlined under Tester Instructions: <ul style="list-style-type: none"> — Perform Solenoid Function Test. — Does solenoid (LED) activate? <p>CAUTION: Do not attempt to pry connector.</p> <ul style="list-style-type: none"> ● Depress tab and pull up on harness. 	Yes No	► GO to A4. ► GO to A5.
A4	TRANSMISSION DRIVE TEST		
	<ul style="list-style-type: none"> ● Perform the Transmission Solenoid Cycling and Drive Test as outlined under tester instructions Step IV. ● Does the vehicle upshift when commanded by the tester? 	Yes No	► REFER to the Powertrain Control/Emissions Diagnosis Manual ⁶ to diagnose EEC-IV microprocessor or vehicle harness concerns. ERASE all codes and PERFORM the Drive Cycle Test as outlined. RE-RUN Self Test. If codes are still present, REFER to the Hydraulic/Mechanical Diagnosis. ► GO to A5.
A5	CHECK RESISTANCE OF SOLENOID/HARNESS		
	<p>NOTE: Refer to the AOD-E Transmission Tester for terminal locations.</p> <ul style="list-style-type: none"> ● Rotate gear selector switch to OFF position. ● Connect power plug into cigar lighter receptacle. ● Connect ohmmeter negative lead to SS-1 jack and positive lead to VPWR jack on tester. This is to test SS-1. ● Record resistance. ● Resistance should be between 20 and 30 ohms. ● Connect ohmmeter negative lead to SS-2 jack and positive lead to VPWR jack on tester. This is to test SS-2. ● Record resistance. ● Resistance should be between 20 and 30 ohms. ● Is resistance between 20 and 30 ohms? 	Yes No	► GO to A6. ► GO to A7. NOTE: Out of specification may be caused by internal harness or solenoid concerns.

6 Can be purchased as a separate item.



Technical Service Information

PINPOINT TEST A: FAULT CODES: 617, 618, 619, 621, 622 (Continued)

TEST STEP		RESULT	ACTION TO TAKE						
A6	CHECK SOLENOID/HARNESS FOR SHORT TO GROUND								
	<ul style="list-style-type: none"> Check for continuity between BAT- (engine ground) and appropriate jack with an ohmmeter or other low current tester (less than 200 milliamps). <table border="1" style="margin-left: 40px;"> <thead> <tr> <th>Solenoid</th> <th>Tester Jack</th> </tr> </thead> <tbody> <tr> <td>SS-1</td> <td>SS-1/VPWR</td> </tr> <tr> <td>SS-2</td> <td>SS-2/VPWR</td> </tr> </tbody> </table> <ul style="list-style-type: none"> Connection should show infinite resistance (no continuity). Is there continuity? 	Solenoid	Tester Jack	SS-1	SS-1/VPWR	SS-2	SS-2/VPWR	Yes No	► GO to A7. ► GO to Hydraulic/Mechanical diagnosis.
Solenoid	Tester Jack								
SS-1	SS-1/VPWR								
SS-2	SS-2/VPWR								
A7	AOD-E INTERNAL ELECTRONIC DIAGNOSTICS								
	<ul style="list-style-type: none"> Drain transmission fluid. Remove transmission pan. Check that the internal harness connector is fully engaged on the shift solenoid assembly. Check that the internal harness connector terminals are fully seated in the connector. Inspect the connector for damage. Are above in good condition? 	Yes No	► GO to A8. ► SERVICE as required.						
A8	CHECK INTERNAL AOD-E HARNESS (Continuity)								
	<ul style="list-style-type: none"> Disconnect internal harness from solenoid assembly (3 wire connector). For SS-1, connect the positive lead from an ohmmeter to the tester jack SS-1 and the negative lead at the White wire of the 3 wire connector. Record resistance. Resistance should be less than 0.5 ohms. For SS-2, connect the positive lead from an ohmmeter to the tester jack SS-2 and the negative lead at the Black wire of the 3 wire connector. Record resistance. Resistance should be less than 0.5 ohms. For VPWR, connect positive lead to VPWR and the negative lead to the White/Black wire of the 3 wire connector. <p>CAUTION: Do not probe into connector terminals.</p> <ul style="list-style-type: none"> Record resistance. Resistance should be less than 0.5 ohms. Is resistance less than 0.5 ohms? 	Yes No	► GO to A9. ► REPLACE harness.						

PINPOINT TEST A: FAULT CODES: 617, 618, 619, 621, 622 (Continued)

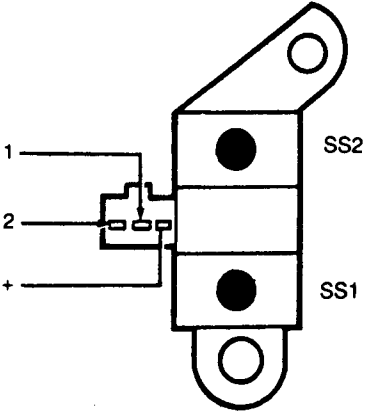
TEST STEP		RESULT	ACTION TO TAKE								
A9	CHECK INTERNAL AOD-E HARNESS (SHORTS TO GROUND) <ul style="list-style-type: none"> Check for continuity between BAT- (engine ground) and the appropriate wire with an ohmmeter or other low current tester (less than 200 milliamps). <table border="1" data-bbox="378 464 640 600"> <thead> <tr> <th>Solenoid</th> <th>Wire</th> </tr> </thead> <tbody> <tr> <td>SS-1</td> <td>White</td> </tr> <tr> <td>SS-2</td> <td>Black</td> </tr> <tr> <td>VPWR</td> <td>White / Black</td> </tr> </tbody> </table> <ul style="list-style-type: none"> Connection should show infinite resistance (no continuity). Does connection show continuity? 	Solenoid	Wire	SS-1	White	SS-2	Black	VPWR	White / Black	Yes No	REPLACE harness. GO to A10.
Solenoid	Wire										
SS-1	White										
SS-2	Black										
VPWR	White / Black										
A10	CHECK SOLENOID RESISTANCE AT SOLENOID <ul style="list-style-type: none"> Check solenoid resistance by connecting an ohmmeter at the outside and + terminals of the solenoid assembly, this is for SS-2. Record resistance. For SS-1, connect the ohmmeter to the center terminal of the solenoid assembly and to the + terminal (Top Right-White / Black wire terminal). Record resistance. Resistance should be between 20 and 30 ohms.  <ul style="list-style-type: none"> Is resistance between 20 and 30 ohms? 	Yes No	GO to A11. REPLACE solenoid assembly.								



Technical Service Information

PINPOINT TEST A: FAULT CODES: 617, 618, 619, 621, 622 (Continued)

TEST STEP		RESULT	ACTION TO TAKE								
A11	CHECK SOLENOID FOR SHORT TO GROUND										
	<ul style="list-style-type: none"> Check for continuity between engine ground and appropriate terminal with ohmmeter or other low current tester (less than 200 milliamps). <table border="1" data-bbox="305 449 786 611"> <thead> <tr> <th>Solenoid</th> <th>Terminal</th> </tr> </thead> <tbody> <tr> <td>SS-1</td> <td>Center-White wire terminal (1)</td> </tr> <tr> <td>SS-2</td> <td>Top left-Black wire terminal (2)</td> </tr> <tr> <td>PWR</td> <td>Top right-White / Black wire terminal (+)</td> </tr> </tbody> </table> <ul style="list-style-type: none"> Connection should show infinite resistance (no continuity). Does connection show continuity? 	Solenoid	Terminal	SS-1	Center-White wire terminal (1)	SS-2	Top left-Black wire terminal (2)	PWR	Top right-White / Black wire terminal (+)	Yes No	<ul style="list-style-type: none"> REPLACE solenoid assembly. REFER to Hydraulic / Mechanical diagnosis.
Solenoid	Terminal										
SS-1	Center-White wire terminal (1)										
SS-2	Top left-Black wire terminal (2)										
PWR	Top right-White / Black wire terminal (+)										

TD 10436A

PINPOINT TEST B: FAULT CODES: 637 and 638

TEST STEP		RESULT	ACTION TO TAKE
B1	AOD-E ELECTRONIC DIAGNOSTICS		
	<ul style="list-style-type: none"> The following items must be checked before proceeding: <ul style="list-style-type: none"> Check the EEC-IV microprocessor assembly for proper function (Self Test) Check the vehicle wiring harness for continuity and shorts to ground. Make sure all connectors are engaged properly. Make sure all terminals in the connectors are properly seated. Check all connectors for damage, corrosion, water, bent pins and missing or damaged seals. Have the items above been checked? 	Yes No	<ul style="list-style-type: none"> GO to B2. PERFORM checks.
B2	CHECK HARNESS CONNECTIONS		
	<ul style="list-style-type: none"> Check that vehicle harness connector is fully engaged on transmission connector. Check that vehicle harness connector terminals are fully engaged in connector. Are terminals fully engaged? 	Yes No	<ul style="list-style-type: none"> GO to B3. SERVICE as required.



Technical Service Information

PINPOINT TEST B: FAULT CODES: 637 and 638 (Continued)

TEST STEP	RESULT	ACTION TO TAKE																								
B3 CHECK RESISTANCE OF TOT SENSOR/HARNESS NOTE: Refer to the AOD-E Transmission Tester for terminal locations. <ul style="list-style-type: none"> ● Disconnect vehicle harness at transmission. ● Install Transmission Tester 007-00085 or equivalent to transmission connector. ● Connect ohmmeter negative lead to -TOT jack and positive lead to +TOT jack on tester. ● Record resistance. ● Resistance should be approximately in the following ranges. ● Is resistance in range? <table border="1" style="margin-left: auto; margin-right: auto;"> <thead> <tr> <th colspan="3">TRANSMISSION FLUID TEMPERATURE</th> </tr> <tr> <th>°C</th> <th>°F</th> <th>Resistance (Ohms)</th> </tr> </thead> <tbody> <tr> <td>0-20</td> <td>32-58</td> <td>37K-100K</td> </tr> <tr> <td>21-40</td> <td>59-104</td> <td>18K-37K</td> </tr> <tr> <td>41-70</td> <td>105-158</td> <td>5K-16K</td> </tr> <tr> <td>71-90</td> <td>159-194</td> <td>2.7K-5K</td> </tr> <tr> <td>91-110</td> <td>195-230</td> <td>1.5K-2.7K</td> </tr> <tr> <td>111-130</td> <td>231-266</td> <td>0.8K-1.5K</td> </tr> </tbody> </table> <p>CAUTION: Do not attempt to pry connector. Depress tab and pull up on harness.</p>	TRANSMISSION FLUID TEMPERATURE			°C	°F	Resistance (Ohms)	0-20	32-58	37K-100K	21-40	59-104	18K-37K	41-70	105-158	5K-16K	71-90	159-194	2.7K-5K	91-110	195-230	1.5K-2.7K	111-130	231-266	0.8K-1.5K	Yes No	<ul style="list-style-type: none"> ▶ GO to B4. ▶ REFER to NOTE below before proceeding to Test Step B4. <p>NOTE: If resistance was not in appropriate temperature range but was between 0.8K and 100K ohms, perform following test. If transmission is cold, run transmission to heat it up. If transmission is warm, allow transmission to cool. Check TOT sensor resistance again. Compare resistance with initial resistance. Resistance should decrease if transmission was heated and should increase if transmission was allowed to cool. If correct change in resistance occurs, REPEAT Quick Test.</p>
TRANSMISSION FLUID TEMPERATURE																										
°C	°F	Resistance (Ohms)																								
0-20	32-58	37K-100K																								
21-40	59-104	18K-37K																								
41-70	105-158	5K-16K																								
71-90	159-194	2.7K-5K																								
91-110	195-230	1.5K-2.7K																								
111-130	231-266	0.8K-1.5K																								
B4 CHECK TOT SENSOR/HARNESS FOR SHORT TO GROUND <ul style="list-style-type: none"> ● Check for continuity between BAT- (engine ground) and appropriate jack (-TOT and +TOT) with ohmmeter or other low current tester (less than 200 milliamps). ● Connection should show infinite resistance (no continuity). ● Is there continuity? 	Yes No	<ul style="list-style-type: none"> ▶ GO to B5. ▶ If TOT was in specification, REFER to the Powertrain Control/Emissions Diagnosis Manual⁷ to diagnose harness or microprocessor. If TOT was out of specification GO to B5. 																								
B5 AOD-E INTERNAL ELECTRONIC DIAGNOSTICS <ul style="list-style-type: none"> ● Drain transmission fluid. ● Remove transmission pan. ● Check that internal harness connector is fully engaged on TOT sensor. ● Check that internal harness connector terminals are fully seated in connector. ● Inspect the connector for damage. ● Are above in good condition? 	Yes No	<ul style="list-style-type: none"> ▶ GO to B6. ▶ SERVICE as required. 																								

⁷ Can be purchased as a separate item.



Technical Service Information

PINPOINT TEST B: FAULT CODES: 637 and 638 (Continued)

TEST STEP		RESULT	ACTION TO TAKE						
B6	CHECK INTERNAL AOD-E HARNESS (CONTINUITY) <ul style="list-style-type: none">● Disconnect internal harness from TOT sensor.● For TOT, connect the positive lead from an ohmmeter to the tester +TOT jack and the negative lead at the White / Red wire of the TOT sensor connector.● Record resistance. Resistance should be less than 0.5 ohms.● Connect the positive lead from an ohmmeter to the tester -TOT jack and the negative lead at the red wire of the TOT wire connector. <p>CAUTION: Do not probe into connector terminals.</p> <ul style="list-style-type: none">● Record resistance. Resistance should be less than 0.5 ohms.● Is resistance less than 0.5 ohms?	Yes No	▶ GO to B7 . ▶ REPLACE harness. GO to B8 .						
B7	CHECK INTERNAL AOD-E HARNESS (SHORTS TO GROUND) <ul style="list-style-type: none">● Check for continuity between BAT- (engine ground) and the appropriate wire (+TOT and -TOT) with ohmmeter or other low current tester (less than 200 milliamps). <table border="1"><thead><tr><th>Sensor</th><th>Wire</th></tr></thead><tbody><tr><td>TOT+</td><td>White / Red</td></tr><tr><td>TOT-</td><td>Red</td></tr></tbody></table> <ul style="list-style-type: none">● Connection should show infinite resistance (no continuity).● Is there continuity?	Sensor	Wire	TOT+	White / Red	TOT-	Red	Yes No	▶ REPLACE harness. GO to B8 . ▶ GO to B8 .
Sensor	Wire								
TOT+	White / Red								
TOT-	Red								



Technical Service Information

PINPOINT TEST B: FAULT CODES: 637 and 638 (Continued)

TEST STEP		RESULT	ACTION TO TAKE																								
B8	CHECK TOT SENSOR RESISTANCE																										
<ul style="list-style-type: none"> ● Check sensor resistance by connecting an ohmmeter at the terminals of the TOT sensor assembly. ● Record resistance. ● Resistance should be in range of temperature of the vehicle. ● Resistance should be approximately in the following ranges. ● Is resistance in range? <table border="1" data-bbox="323 621 675 940"> <thead> <tr> <th colspan="3">TRANSMISSION FLUID TEMPERATURE</th> </tr> <tr> <th>°C</th> <th>°F</th> <th>Resistance (Ohms)</th> </tr> </thead> <tbody> <tr> <td>0-20</td> <td>32-58</td> <td>37K-100K</td> </tr> <tr> <td>21-40</td> <td>59-104</td> <td>16K-37K</td> </tr> <tr> <td>41-70</td> <td>105-158</td> <td>5K-16K</td> </tr> <tr> <td>71-90</td> <td>159-194</td> <td>2.7K-5K</td> </tr> <tr> <td>91-110</td> <td>195-230</td> <td>1.5K-2.7K</td> </tr> <tr> <td>111-130</td> <td>231-266</td> <td>0.8K-1.5K</td> </tr> </tbody> </table>		TRANSMISSION FLUID TEMPERATURE			°C	°F	Resistance (Ohms)	0-20	32-58	37K-100K	21-40	59-104	16K-37K	41-70	105-158	5K-16K	71-90	159-194	2.7K-5K	91-110	195-230	1.5K-2.7K	111-130	231-266	0.8K-1.5K	Yes No	► GO to B9. ► REPLACE TOT sensor.
TRANSMISSION FLUID TEMPERATURE																											
°C	°F	Resistance (Ohms)																									
0-20	32-58	37K-100K																									
21-40	59-104	16K-37K																									
41-70	105-158	5K-16K																									
71-90	159-194	2.7K-5K																									
91-110	195-230	1.5K-2.7K																									
111-130	231-266	0.8K-1.5K																									
B9	CHECK TOT SENSOR FOR SHORT TO GROUND																										
<ul style="list-style-type: none"> ● Check for continuity between engine ground and appropriate terminal with ohmmeter or other low current tester (less than 200 milliamps). <table border="1" data-bbox="393 1125 607 1226"> <thead> <tr> <th>Sensor</th> <th>Terminal</th> </tr> </thead> <tbody> <tr> <td>TOT+</td> <td>Outside+</td> </tr> <tr> <td>TOT-</td> <td>Outside-</td> </tr> </tbody> </table> <ul style="list-style-type: none"> ● Connection should show infinite resistance (no continuity). ● Is there continuity? 		Sensor	Terminal	TOT+	Outside+	TOT-	Outside-	Yes No	► REPLACE TOT assembly. ► REFER to the Powertrain Control/Emissions Diagnosis Manual ⁸ to diagnose harness or microprocessor concerns.																		
Sensor	Terminal																										
TOT+	Outside+																										
TOT-	Outside-																										

⁸ Can be purchased as a separate item.



Technical Service Information

PINPOINT TEST C: FAULT CODES: 628 and 652

TEST STEP		RESULT	ACTION TO TAKE
C1	AOD-E ELECTRONIC DIAGNOSTICS		
	<ul style="list-style-type: none"> ● The following items must be checked before proceeding: <ul style="list-style-type: none"> — Check the EEC-IV microprocessor assembly for proper function (Self Test). — Check vehicle wiring harness for continuity and shorts to ground. — Make sure all connectors are engaged properly. — Make sure all terminals in connectors are properly seated. — Check all connectors for damage, corrosion, water, bent pins and missing or damaged seals. ● Have items been checked? 	Yes No	► GO to C2. ► PERFORM checks.
C2	CHECK HARNESS CONNECTIONS		
	<ul style="list-style-type: none"> ● Check that vehicle harness connector is fully engaged on transmission connector. ● Check that vehicle harness connector terminals are fully engaged in connector. ● Are terminals fully engaged? 	Yes No	► GO to C3. ► SERVICE as required.
C3	TRANSMISSION FUNCTIONAL TEST		
	<ul style="list-style-type: none"> ● Disconnect vehicle harness at transmission. ● Install tester to transmission connector. ● Using tests outlined under Tester Instructions. <ul style="list-style-type: none"> — Perform MCCC solenoid function test. ● Does MCCC (LED) activate when tester switch is depressed? <p>CAUTION: Do not pry connector. Depress the tab and pull on vehicle harness.</p>	Yes No	► GO to C4. ► GO to C5.
C4	TRANSMISSION DRIVE TEST		
	<ul style="list-style-type: none"> ● Perform Transmission Solenoid Cycling and Drive Cycle Test as outlined under Testing Instructions. ● While in second gear depress the MCCC switch. ● Does the MCCC activate? ● Does the engine rpm drop? 	Yes No	► REFER to Powertrain Control/Emissions Diagnosis Manual ⁹ to diagnose microprocessor and vehicle harness concerns. ► GO to C5.
C5	CHECK RESISTANCE OF SOLENOID/HARNESS		
	<p>NOTE: Refer to AOD-E Transmission Tester for terminal locations.</p> <ul style="list-style-type: none"> ● Connect ohmmeter negative lead to MCCC (jack) and positive lead to VPWR on tester. This is to test MCCC. ● Record resistance. ● Resistance should be between 1 and 3 ohms. ● Is resistance between 1 and 3 ohms? 	Yes No	► GO to C6. ► Internal harness or solenoid may be damaged. GO to C7.



Technical Service Information

PINPOINT TEST C: FAULT CODES: 628 and 652 (Continued)

TEST STEP		RESULT	ACTION TO TAKE						
C6	CHECK SOLENOID / HARNESS FOR SHORT TO GROUND								
<ul style="list-style-type: none"> Check for continuity between BAT- (engine ground) and appropriate jack with an ohmmeter or other low current tester (less than 200 milliamps). <table border="1" style="margin-left: 40px;"> <thead> <tr> <th>Solenoid</th> <th>Tester Jack</th> </tr> </thead> <tbody> <tr> <td>MCCC</td> <td>MCCC</td> </tr> <tr> <td>VPWR</td> <td>VPWR</td> </tr> </tbody> </table> <ul style="list-style-type: none"> Connection should infinite resistance (no continuity). Is there continuity? 		Solenoid	Tester Jack	MCCC	MCCC	VPWR	VPWR	Yes No	GO to C7. REFER to Hydraulic / Mechanical Diagnosis.
Solenoid	Tester Jack								
MCCC	MCCC								
VPWR	VPWR								
C7	AOD-E INTERNAL ELECTRONIC DIAGNOSTICS								
<ul style="list-style-type: none"> Drain transmission fluid. Remove transmission pan. Check that internal harness connector is fully engaged on the shift solenoid assembly. Check that internal harness connector terminals are fully seated in the connector. Inspect the connector for damage. Is above in good condition? 		Yes No	GO to C8. SERVICE as required.						
C8	CHECK INTERNAL AOD-E HARNESS (CONTINUITY)								
<ul style="list-style-type: none"> Disconnect internal harness from solenoid body assembly. (MCCC wire connector). For MCCC, connect positive lead from an ohmmeter to tester MCCC jack and the negative lead at the green wire of the MCCC connector. Record resistance. Resistance should be less than 0.5 ohms. Connect the positive lead from an ohmmeter to the tester VPWR jack and the negative lead to the White / Green wire of the MCCC connector. <p>CAUTION: Do not probe into connector terminals.</p> <ul style="list-style-type: none"> Record resistance. Resistance should be less than 0.5 ohms. Is resistance less than 0.5 ohms? 		Yes No	GO to C9. REPLACE harness.						



Technical Service Information

PINPOINT TEST C: FAULT CODES: 628 and 652 (Continued)

TEST STEP		RESULT	ACTION TO TAKE						
C9	CHECK INTERNAL AOD-E HARNESS (SHORTS TO GROUND)								
	<ul style="list-style-type: none"> Check for continuity between BAT- (engine ground) and the appropriate wire with an ohmmeter or other low current tester (less than 200 milliamps). <table border="1" style="margin-left: 40px;"> <thead> <tr> <th>Solenoid</th> <th>Wire</th> </tr> </thead> <tbody> <tr> <td>MCCC</td> <td>Green</td> </tr> <tr> <td>VPWR</td> <td>White/Green</td> </tr> </tbody> </table> <ul style="list-style-type: none"> Connection should show infinite resistance (no continuity). Is there continuity? 	Solenoid	Wire	MCCC	Green	VPWR	White/Green	Yes No	REPLACE harness. GO to C10.
Solenoid	Wire								
MCCC	Green								
VPWR	White/Green								
C10	CHECK SOLENOID RESISTANCE								
	<ul style="list-style-type: none"> Check solenoid resistance by connecting an ohmmeter to the terminals of the solenoid assembly, this is for MCCC. Record resistance. Resistance should be between 1 and 3 ohms. Is resistance between 1 and 3 ohms? 	Yes No	GO to C11. REPLACE solenoid assembly.						
C11	CHECK SOLENOID FOR SHORT TO GROUND								
	<ul style="list-style-type: none"> Check for continuity between engine ground and appropriate solenoid terminals with ohmmeter or other low current tester (less than 200 milliamps). <table border="1" style="margin-left: 40px;"> <thead> <tr> <th>Solenoid</th> <th>Terminal</th> </tr> </thead> <tbody> <tr> <td>MCCC</td> <td>Outside</td> </tr> <tr> <td>VPWR</td> <td>Outside</td> </tr> </tbody> </table> <ul style="list-style-type: none"> Connection should infinite resistance (no continuity). Is there continuity? 	Solenoid	Terminal	MCCC	Outside	VPWR	Outside	Yes No	REPLACE solenoid assembly. REFER to Hydraulic/Mechanical Diagnosis.
Solenoid	Terminal								
MCCC	Outside								
VPWR	Outside								

TD10438A

PINPOINT TEST D: FAULT CODE: 634, MLPS ERROR DETECTED

TEST STEP		RESULT	ACTION TO TAKE
D1	AOD-E ELECTRONIC DIAGNOSTICS		
	<ul style="list-style-type: none"> The following items must be checked before proceeding: <ul style="list-style-type: none"> Check the EEC-IV microprocessor assembly for proper function (Self Test). Check the vehicle wiring harness for continuity and shorts to ground. Make sure all connectors are engaged properly. Make sure all terminals in the connectors are properly seated. Check all connectors for damage, corrosion, water, bent pins and missing or damaged seals. Have the items above been checked? 	Yes No	GO to D2. PERFORM checks.



Technical Service Information

PINPOINT TEST E: FAULT CODES: 624, 625, EPC CIRCUIT FAILURES

TEST STEP		RESULT	ACTION TO TAKE
E1	AOD-E ELECTRONIC DIAGNOSTICS		
	<ul style="list-style-type: none"> ● The following items must be checked before proceeding: <ul style="list-style-type: none"> — Check the EEC-IV microprocessor assembly for proper function (Self-Test). — Check the vehicle wiring harness for continuity and shorts to ground. — Make sure all connectors are engaged properly. — Make sure all terminals in the connectors are properly seated. — Check all connectors for damage, corrosion, water, bent pins and missing or damaged seals. ● Have the items above been checked? 	Yes No	► GO to E2. ► PERFORM checks.
E2	CHECK HARNESS CONNECTIONS		
	<ul style="list-style-type: none"> ● Check that vehicle harness connector is fully engaged on transmission connector. ● Check that vehicle harness connector terminals are fully engaged in connector. ● Are terminals fully engaged? 	Yes No	► GO to E3. ► SERVICE as required.
E3	TRANSMISSION FUNCTIONAL TEST		
	<ul style="list-style-type: none"> ● Disconnect vehicle harness at transmission. ● Install line pressure gauge at line tap on case. ● Install EPC pressure gauge at TV tap on case. ● Install Transmission Tester 007-00085 or equivalent to transmission connector. ● Using tests outlined under Tester Instructions: <ul style="list-style-type: none"> — Perform EPC Function Test. — Does the EPC (LED) activate when EPC switch is depressed? — Observe line pressure on the gauge while depressing EPC switch (vehicle must be running). — Do the line pressure and EPC pressure gauges show acceptable pressures? <p>CAUTION: Do not attempt to pry the connector. Depress the tab and pull up on the vehicle harness.</p>	Yes No	► REFER to Powertrain Control/Emissions Diagnosis Manual ¹¹ to diagnose microprocessor or vehicle harness. ► GO to E4.
E4	CHECK RESISTANCE OF SOLENOID/HARNESS		
	<p>NOTE: Refer to the AOD-E Transmission Tester for terminal locations.</p> <ul style="list-style-type: none"> ● Connect ohmmeter negative lead to VPWR jack and positive lead to EPC jack on tester. This is to test EPC solenoid. ● Record resistance. ● Resistance should be between 2.48 and 5.66 ohms. ● Is resistance between 2.48 and 5.66 ohms? 	Yes No	► GO to E5. ► Internal harness or solenoid may be damaged. GO to E6.

11 Can be purchased as a separate item.



Technical Service Information

PINPOINT TEST E: FAULT CODES: 624, 625, EPC CIRCUIT FAILURES (Continued)

TEST STEP		RESULT	ACTION TO TAKE						
E5	CHECK SOLENOID/HARNESS FOR SHORT TO GROUND								
	<ul style="list-style-type: none"> Check for continuity between BAT- (engine ground) and appropriate jack with an ohmmeter or other low current tester (less than 200 milliamps). <table border="1" data-bbox="391 499 646 604"> <thead> <tr> <th>Solenoid</th> <th>Tester Jack</th> </tr> </thead> <tbody> <tr> <td>EPC</td> <td>EPC</td> </tr> <tr> <td>EPCPWR</td> <td>VPWR</td> </tr> </tbody> </table> <ul style="list-style-type: none"> Connection should show infinite resistance (no continuity). Is there continuity? 	Solenoid	Tester Jack	EPC	EPC	EPCPWR	VPWR	Yes No	<ul style="list-style-type: none"> GO to E6. REFER to the Powertrain Control/Emissions Diagnosis Manual¹² to diagnose EEC-IV microprocessor or vehicle harness.
Solenoid	Tester Jack								
EPC	EPC								
EPCPWR	VPWR								
E6	AOD-E INTERNAL ELECTRONIC DIAGNOSTICS								
	<ul style="list-style-type: none"> Drain transmission fluid. Remove transmission pan. Check that internal harness connector is fully engaged on shift solenoid assembly. Check that internal harness connector terminals are fully seated in connector. Inspect connector for damage. Are above in good condition? 	Yes No	<ul style="list-style-type: none"> GO to E7. SERVICE as required. 						
E7	CHECK INTERNAL AOD-E HARNESS (CONTINUITY)								
	<ul style="list-style-type: none"> Disconnect internal harness from EPC solenoid assembly. For EPC, connect the positive lead from an ohmmeter to the tester EPC jack and the negative lead at the Blue wire at the EPC wire connector. Record resistance. Resistance should be less than 0.5 ohms. For EPC PWR, connect the positive lead from an ohmmeter to the tester VPWR jack and the negative lead at the White/Blue wire at the EPC wire connector. Record resistance. Resistance should be less than 0.5 ohms. Is resistance less than 0.5 ohms? 	Yes No	<ul style="list-style-type: none"> GO to E8. REPLACE harness. 						

12 Can be purchased as a separate item.



Technical Service Information

PINPOINT TEST E: FAULT CODES: 624, 625, EPC CIRCUIT FAILURES (Continued)

TEST STEP		RESULT	ACTION TO TAKE						
E8	CHECK INTERNAL AOD-E HARNESS (SHORTS TO GROUND)								
	<ul style="list-style-type: none"> Check for continuity between BAT- (engine ground) and the appropriate wire with an ohmmeter or other low current tester (less than 200 milliamps). <table border="1" style="margin-left: 40px;"> <thead> <tr> <th>Solenoid</th> <th>Wire</th> </tr> </thead> <tbody> <tr> <td>EPC</td> <td>Blue</td> </tr> <tr> <td>EPCPWR</td> <td>White / Blue</td> </tr> </tbody> </table> <ul style="list-style-type: none"> Connection should show infinite resistance (no continuity). Is there continuity? 	Solenoid	Wire	EPC	Blue	EPCPWR	White / Blue	Yes No	► REPLACE harness. ► GO to E9.
Solenoid	Wire								
EPC	Blue								
EPCPWR	White / Blue								
E9	CHECK SOLENOID RESISTANCE								
	<ul style="list-style-type: none"> Check solenoid resistance by connecting an ohmmeter at the EPC terminals of the solenoid assembly. Record resistance. Resistance should be between 2.48 and 5.66 ohms. Is resistance between 2.48 and 5.66 ohms? 	Yes No	► GO to E10. ► REPLACE solenoid assembly.						
E10	CHECK SOLENOID FOR SHORT TO GROUND								
	<ul style="list-style-type: none"> Check for continuity between engine ground and appropriate terminal with ohmmeter or other low current tester (less than 200 milliamps). <table border="1" style="margin-left: 40px;"> <thead> <tr> <th>Solenoid</th> <th>Terminal</th> </tr> </thead> <tbody> <tr> <td>EPC</td> <td>OUTSIDE</td> </tr> <tr> <td>EPCPWR</td> <td>OUTSIDE</td> </tr> </tbody> </table> <ul style="list-style-type: none"> Connection should not show continuity (infinite). Is there continuity? 	Solenoid	Terminal	EPC	OUTSIDE	EPCPWR	OUTSIDE	Yes No	► REPLACE solenoid assembly. ► REFER to Hydraulic / Mechanical Diagnosis.
Solenoid	Terminal								
EPC	OUTSIDE								
EPCPWR	OUTSIDE								

PINPOINT TEST F: FAULT CODE: 639 OSS—INSUFFICIENT INPUT

TEST STEP		RESULT	ACTION TO TAKE
F1	AOD-E ELECTRONIC DIAGNOSTICS		
	<ul style="list-style-type: none"> The following items must be checked before proceeding: <ul style="list-style-type: none"> Check the EEC-IV microprocessor assembly for proper function (Self Test). Check vehicle wiring harness for continuity and shorts to ground. Make sure all connectors are engaged properly. Make sure all terminals in the connectors are properly seated. Check all connectors for damage, corrosion, water, bent pins and missing or damaged seals. Have items above been checked? 	Yes No	► GO to F2. ► PERFORM checks.



Technical Service Information

PINPOINT TEST F: FAULT CODE: 639 OSS—INSUFFICIENT INPUT (Continued)

TEST STEP		RESULT	ACTION TO TAKE						
F2	CHECK HARNESS CONNECTIONS								
	<ul style="list-style-type: none"> • Check that vehicle harness connector is fully engaged on output shaft speed (OSS) sensor. • Check that vehicle harness connector terminals are fully engaged in connector. • Are terminals fully engaged? 	Yes No	► GO to F3. ► SERVICE as required.						
F3	TRANSMISSION FUNCTIONAL TEST								
	<ul style="list-style-type: none"> • Disconnect vehicle harness at OSS sensor. • Install Transmission Tester 007-00085 or equivalent onto OSS sensor. • Connect voltmeter positive lead to +OSS and the negative lead to -OSS. Set voltmeter to AC. • Perform Drive Test. Monitor voltmeter. • Does the voltage increase with an increase in vehicle speed? <p>CAUTION: Do not attempt to pry on the connector. Depress tabs and pull up on the harness.</p>	Yes No	► REFER to the Powertrain Control / Emissions Diagnosis Manual ¹³ to diagnose vehicle harness or microprocessor concerns. ► GO to F4.						
F4	CHECK RESISTANCE OF OUTPUT SHAFT SPEED SENSOR								
	<p>NOTE: Refer to the AOD-E Transmission Tester for terminal locations.</p> <ul style="list-style-type: none"> • Connect ohmmeter negative lead to +OSS jack and positive lead to -OSS jack on tester. • Record resistance. Resistance should be between 450 and 750 ohms. • Is resistance between 450 and 750 ohms? 	Yes No	► GO to F5. ► REPLACE sensor.						
F5	CHECK SENSOR FOR SHORT TO GROUND								
	<ul style="list-style-type: none"> • Check for continuity between BAT- (engine ground) and appropriate jack with an ohmmeter or other low current tester (less than 200 milliamps). <table border="1" style="margin-left: 40px;"> <thead> <tr> <th>Solenoid</th> <th>Tester Jack</th> </tr> </thead> <tbody> <tr> <td>OSS+</td> <td>+OSS</td> </tr> <tr> <td>OSS-</td> <td>-OSS</td> </tr> </tbody> </table> <ul style="list-style-type: none"> • Connection should show infinite resistance (no continuity). • Is there continuity? 	Solenoid	Tester Jack	OSS+	+OSS	OSS-	-OSS	Yes No	► REPLACE sensor. ► REFER to Hydraulic / Mechanical Diagnosis.
Solenoid	Tester Jack								
OSS+	+OSS								
OSS-	-OSS								

Diagnostic Hydraulic / Mechanical Chart Instructions

The AOD-E Hydraulic / Mechanical charts are used to separate electrical from mechanical causes or concerns.

Refer to the following guidelines:

1. Define major concern.
2. Eliminate possible causes in the electrical cause / concern column 200 numbers.
3. Eliminate possible causes in the hydraulic / mechanical cause / concern column 300 numbers.



Technical Service Information

NOTE: The items listed under the main headings are arranged in order of most probable cause first.

DIAGNOSTIC ROUTINES INDEX

TITLE	ROUTINES	
	ELECTRICAL (See Note)	MECHANICAL HYDRAULIC
Engagement Concerns		
No Forward	201	301
No Reverse	202	302
Harsh Reverse	203	303
Harsh Forward	204	304
Delayed/Soft Reverse	205	305
Delayed/Soft Forward	206	306
Shift Concerns		
Some / All Shifts Missing	210	310
Timing Concerns		
—Early/Late	211	311
—Erratic	212	312
Feel		
—Soft/Slipping	213	313
—Harsh	214	314
No First Gear, Engages in Higher Gear	215	315
No Manual First Gear	216	316
Converter Operation Concerns		
Converter: No Apply	240	340
Converter: Always Applied / Stalls Vehicle	241	341
Converter: Cycling / Shudder / Chatter	242	342
Other Concerns		
No Engine Braking in 2nd Gear, Manual 1st Position	250	350
Shift Lever Efforts High	251	351
External Leaks	252	352
Poor Vehicle Acceleration	253	353
Noise / Vibration - Forward or Reverse	254	354
Engine will not Crank	255	355
No Park Range	256	356
Overheating	257	357
Reference		
Diagnostic Pressure Chart		401

NOTE: Perform electrical routine first.



Technical Service Information

No Forward Engagements

Possible Component	Reference / Action
201 — ELECTRICAL ROUTINE	
No Electrical Concerns	
301 — HYDRAULIC/MECHANICAL ROUTINE	
Fluid —Improper level —Condition	—Adjust fluid to proper level. —Inspect per instructions under Fluid Condition Check.
Shift Linkage —Damaged, misadjusted	—Inspect and service as required. Adjust linkage as outlined. After servicing linkage, verify MLPS sensor is properly adjusted. Refer to Transmission, Assembly.
Improper Pressures —Low Forward Clutch pressure, Low line pressure	—Check pressure line and forward clutch tap. Refer to Pressure Chart for specification. If pressures are low, check the following possible components: oil filter and seal assembly, main controls, pump assembly, forward clutch assembly.
Oil Filter and Seal Assembly —Plugged, damaged —Filter seal damaged	—Replace filter and seal assembly.
Main Controls —3-4 shift valve, main regulator valve, orifice control valve, manual valve stuck, damaged —Bolts not tightened to specification —Gaskets damaged —2-3 accumulator and seals damaged	—Inspect and service as required. —Retighten bolts to specification. —Inspect gasket for damage and replace as required. —Inspect piston, seals and bore for damage and replace as required.
Pump Assembly —Bolts not tightened to specification —Porosity / cross leaks and ball missing or leaking, plugged hole —No. 3 and No. 4 seal rings damaged —Gaskets damaged	—Retighten bolts to specification. —Inspect for porosity and leaks. Replace as required. —Inspect seals for damage, replace as required. —Inspect for damage and replace.
Forward Clutch Assembly —Seals, piston —Check balls —Friction Elements —Damaged or worn	—Inspect seals for damage and replace as required. —Inspect for mislocation, poor seating damage. Replace cylinder as required. —Check for abnormal wear, damage. Replace as required.
Low One-Way Clutch Assembly (Planetary) —Worn, damaged or misassembled	—Inspect for damage. Service as required.
Output Shaft —Sleeve / pin damaged	—Inspect for damage. Service as required.



Technical Service Information

No Reverse Engagement

Possible Component	Reference/Action
202 — ELECTRICAL ROUTINE	
No Electrical Concerns	
302 — HYDRAULIC/MECHANICAL ROUTINE	
Fluid —Improper level —Condition	—Adjust fluid to proper level. —Inspect as outlined under Fluid Condition Check.
Shift Linkage —Damaged or misadjusted	—Inspect and service as required. Adjust linkage as outlined. After servicing linkage, verify that the MLPS sensor is properly adjusted. Refer to Transmission, Assembly.
Improper Pressures —Low reverse clutch pressure —Low reverse band pressure —Low line pressure	—Check pressure at line pressure tap. Refer to Hydraulic Pressure Chart for specifications. If pressures are low, check the following possible components: oil filter and seal assembly, main control, reverse servo, pump assembly, reverse clutch assembly.
Oil Filter and seal assembly —Plugged or damaged	—Replace filter and seal assembly.
Main Controls —No. 6 shuttle ball, manual valve, main regulator valve, 1-2 accumulator seals stuck or damaged —Bolts not tightened to specification. —Gasket damaged	—Inspect for damage, service as required. —Retighten bolts to specification. —Inspect for damage and replace as required.
Low Reverse Servo —Seals damaged (piston and cover) —Servo cover retaining ring misassembled —Anchor pins damaged	—Inspect for damage. Service as required.
Pump Assembly —Bolts not tightened to specification. —Porosity / cross leaks / ball missing or leaking, plugged hole —Gasket damaged —No. 1 and 2 seal ring	—Retighten bolts to specification. —Replace pump assembly. —Inspect for damage and replace as required. —Inspect for damage and replace as required.
Reverse Clutch Assembly —Seals, piston —Check ball —Friction elements damaged or worn	—Inspect for damage. Service as required.
Low Reverse Band —Band, servo, anchor pins damaged or worn	—Inspect for damage. Service as required.



Technical Service Information

Harsh Reverse Engagement

Possible Component	Reference/Action
203 — ELECTRICAL ROUTINE	
Engine Concerns —TP, MAF, EDIS, ACT, ISC, EEC-IV microprocessor vehicle wiring harness	—Run Self Test. —Refer to Powertrain Control/Emissions Diagnosis Manual ¹ for diagnosis of TP, MAF, EDIS, ACT, ISC.
Transmission Concerns —EPC, TOT	—Run Self Test. —Perform transmission pinpoint test with tester. Service as required. —Retest and road test.
303 — HYDRAULIC/MECHANICAL ROUTINE	
Fluid —Improper level —Condition	—Adjust fluid to proper level. —Inspect as outlined under Fluid Condition Check.
Shift Linkage —Damaged or misadjusted	—Inspect and service as required. Adjust linkage as outlined. After servicing linkage, verify that the MLPS sensor is properly adjusted. Refer to Transmission, Assembly.
Improper Pressures —High line pressure —High EPC pressure	—Check pressure at line and EPC pressure taps. Refer to Hydraulic Pressure Chart for specifications. If high, check the following possible components: main controls, oil filter and seal assembly.
Oil Filter and Seal Assembly —Plugged or damaged —Filter seal damaged	—Replace filter and seal assembly.
Main Controls —No. 6 Shuttle ball, No. 5 check ball, manual valve, main regulator valve stuck or damaged —Bolts not tightened to specification. —Gasket damaged —EPC solenoid, stuck or damaged	—Inspect for damage, service as required. —Retighten bolts to specification. —Inspect for damage and replace. —Inspect for damage, contamination. Service as required.
Low Reverse - Servo —Seals damaged (piston and cover) —Servo cover retaining ring misassembled. —Anchor pins damaged (case)	—Inspect for damage. Service as required.
Pump Assembly —Bolts not tightened to specification. —Porosity/cross leaks —Gasket damaged —No's 1 and 2 seal ring damage	—Retighten bolts to specification. —Replace pump assembly. —Inspect for damage and replace. —Inspect for damage and replace as required.
Reverse Clutch Assembly —Seals, piston —Check ball —Friction elements damaged, worn —Return spring piston damaged, worn	—Inspect for damage. Service as required.
Low Reverse Band —Band, servo, anchor pin damaged or worn	—Inspect for damage. Service as required.

¹ Can be purchased as a separate item.



Technical Service Information

Harsh Forward Engagement

Possible Component	Reference/Action
204 — ELECTRICAL ROUTINE	
Engine Concerns —TP, MAF, EDIS, ACT, ISC, EEC-IV microprocessor, wiring harness	—Run Self Test. —Refer to Powertrain Control/Emissions Diagnosis Manual ² for diagnosis of TP, MAF, EDIS, ACT, ISC.
Transmission Concerns —EPC, TOT —Solenoid circuit open —Harness, solenoid —Processor driver circuit open	—Run Self Test. —Perform transmission pinpoint test. Service as required. —Retest and road test.
304 — HYDRAULIC/MECHANICAL ROUTINE	
Fluid —Improper level —Condition	—Adjust fluid to proper level. —Inspect as outlined under Fluid Condition Check.
Improper Pressures —High forward clutch pressure, High line pressure, High EPC pressure	—Check pressure at line, EPC and forward pressure taps. Refer to Hydraulic Pressure Chart for specifications. If pressures are high, check the following possible components: main controls, pump assembly.
Main Controls —Main regulator valve, 2-3 Backout valve 2-3 Accumulator seal/retainer stuck, damaged —Bolts not tightened to specification. —Gaskets damaged —EPC solenoid stuck or damaged	—Inspect and service as required. —Retighten bolts to specification. —Inspect for damage and replace as required. —Inspect for damage or contamination. Service as required.
Pump Assembly —Bolts not tightened to specification. —Porosity / cross leaks —Gaskets damaged	—Retighten bolts to specification. —Inspect for porosity/leaks. Replace pump. —Inspect for damage and replace as required.
Forward Clutch Assembly —Check balls —Friction element damaged or worn —Spring, forward clutch wave damaged or worn —Forward clutch return spring damaged or worn	—Inspect for mislocation, poor seating, damage. Replace forward clutch cylinder. —Check for wear or damage, replace as required. —Check for damage, replace as required. —Check for damage, replace as required.



Technical Service Information

Delayed/Soft Reverse Engagement

Possible Component	Reference/Action
205 — ELECTRICAL ROUTINE	
No Electrical Concerns	
305 — HYDRAULIC/MECHANICAL ROUTINE	
Fluid —Improper level —Condition	—Adjust fluid to proper level. —Inspect as outlined under Fluid Condition Check.
Shift Linkage —Damaged, misadjusted	—Inspect and service as required. Adjust linkage as outlined. After servicing linkage, verify that the MLPS sensor is properly adjusted. Refer to Transmission, Assembly.
Improper Pressures —Low reverse clutch pressure —Low reverse band pressure —Low line pressure	—Check pressure at line tap. Refer to Hydraulic Pressure Chart for specifications. If pressures are low, check the following possible components: main control, pump assembly, reverse clutch assembly, reverse servo.
Oil Filter and Seal Assembly —Plugged or damaged —Filter seal damaged	—Replace filter and seal assembly.
Main Controls —No. 6 shuttle ball, 1-2 accumulator seals, manual valve, main regulator valve stuck or damaged —Bolts not tightened to specification. —Gaskets damaged	—Inspect for damage, service as required. —Retighten bolts to specification. —Inspect for damage and replace as required.
Low Reverse Servo —Seals damaged (piston and cover) —Servo cover retaining ring assembled incorrectly.	—Inspect for damage. Service as required.
Pump Assembly —Bolts not tightened to specification. —Porosity/cross leaks/ball missing or leaking —Gaskets damaged —No. 1 and No. 2 seal rings damaged	—Retighten bolts to specification. —Replace pump assembly. —Inspect for damage and replace as required. —Inspect for damage and replace as required.
Reverse Clutch Assembly —Seals, piston —Check ball —Friction elements damaged or worn —Return spring and piston damaged or worn	—Inspect for damage. Service as required.
Low Reverse Band —Damaged or worn	—Inspect for damage. Service as required.



Technical Service Information

Delayed/Soft Forward Engagement

Possible Component	Reference/Action
206 — ELECTRICAL ROUTINE	
No Electrical Concerns	
306 — HYDRAULIC/MECHANICAL ROUTINE	
Fluid —Improper level —Condition	—Adjust fluid to proper level. —Inspect as outlined under Fluid Condition Check.
Shift Linkage —Damaged, misadjusted	—Inspect and service as required. Adjust linkage as outlined. After servicing linkage, verify that the MLPS sensor is properly adjusted. Refer to Transmission, Assembly.
Improper Pressures —Low forward clutch pressure —Low line pressure —Low EPC pressure	—Check pressure at line, forward clutch and EPC taps. Refer to Hydraulic Pressure Chart for specifications. If pressures are low, check the following possible components: oil filter and seal assembly, main controls and pump assembly.
Oil Filter and Seal Assembly —Plugged or damaged —Filter seal damaged	—Replace filter and seal assembly.
Main Controls —3-4 shift valve, main regulator valve, orifice control valve stuck or damaged —Bolts not tightened to specification —Gaskets damaged —2-3 or 1-2 accumulator, seals, bore damaged or stuck —EPC solenoid stuck or damaged	—Inspect; service as required —Retighten bolts to specification. —Inspect for damage and replace. —Inspect for damage and replace. —Inspect for damage or contamination. Service as required.
Pump Assembly —Bolts not tightened to specification. —Porosity/cross leaks —Gaskets damaged —No. 3, No. 4 seal rings damaged	—Retighten bolts to specification. —Inspect for porosity and leaks. Replace as required. —Inspect for damage and replace as required. Inspect for damage and replace as required.
Forward Clutch Assembly —Seals, piston —Check balls —Friction elements damaged or worn	—Inspect seals for damage and replace as required. —Inspect for incorrect location, poor seating damage. Replace cylinder as required. —Check for abnormal wear or damage. Replace as required.



Technical Service Information

Some or All Shifts Missing

Possible Component	Reference/Action														
210 — ELECTRICAL ROUTINE															
Engine Concerns. —TP, MAF, EDIS, VSS, EEC-IV microprocessor, vehicle wiring harness	—Run Self Test. —Refer to Powertrain Control / Emissions Diagnosis Manual ³ for diagnosis. Service as required.														
Transmission Concerns —Shift solenoids, OSS, MLPS	—Run Self Test. Perform transmission pinpoint tests. Service as required. Retest and road test.														
310 — HYDRAULIC/MECHANICAL ROUTINE															
Fluid —Improper level —Condition	—Adjust fluid to proper level. —Inspect as outlined under Fluid Condition Check.														
Shift Linkage —Damaged, misadjusted	—Inspect and service as required. Adjust linkage as outlined. After servicing linkage, verify that the MLPS sensor is properly adjusted. Refer to Transmission, Assembly. —For additional diagnosis, refer to the appropriate shift routine(s) chart: <table border="1" data-bbox="833 909 1397 1098"><thead><tr><th>Shift</th><th>Routine</th></tr></thead><tbody><tr><td>1-2</td><td>220/320</td></tr><tr><td>2-3</td><td>221/321</td></tr><tr><td>3-4</td><td>222/322</td></tr><tr><td>4-3</td><td>223/323</td></tr><tr><td>3-2</td><td>224/324</td></tr><tr><td>2-1</td><td>225/325</td></tr></tbody></table>	Shift	Routine	1-2	220/320	2-3	221/321	3-4	222/322	4-3	223/323	3-2	224/324	2-1	225/325
Shift	Routine														
1-2	220/320														
2-3	221/321														
3-4	222/322														
4-3	223/323														
3-2	224/324														
2-1	225/325														



Technical Service Information

Timing — Early/Late

Possible Component	Reference/Action														
211 — ELECTRICAL ROUTINE															
Engine Concerns —TP, EDIS, MAF, EEC-IV microprocessor, VSS, vehicle wiring harness	—Run Self Test. —Refer to Powertrain Control/Emissions Diagnosis Manual ⁴ for diagnosis.														
Transmission Concerns —EEC-IV microprocessor, OSS, TOT, EPC, Shift solenoids internal transmission harness	—Run Self Test. Perform transmission pinpoint test. Retest and road test.														
311 — HYDRAULIC/MECHANICAL ROUTINE															
Other —Tire size change —Axle ratio change	—Verify vehicle has original equipment. Changes in tire size, axle ratio may affect shift timing.														
Fluid —Improper level —Condition	—Adjust fluid to proper level. —Inspect as outlined under Fluid Condition Check.														
Improper Pressures —Line pressure or EPC pressure	—Check pressure at line and EPC taps. Refer to Hydraulic Pressure Chart for specifications. If not OK, check the main control. If OK refer to the appropriate diagnostic routine. —Refer to the appropriate shift routine(s) for additional diagnosis. <table border="1" style="margin-left: auto; margin-right: auto;"> <thead> <tr> <th>Shift</th> <th>Routine</th> </tr> </thead> <tbody> <tr> <td>1-2</td> <td>320</td> </tr> <tr> <td>2-3</td> <td>321</td> </tr> <tr> <td>3-4</td> <td>322</td> </tr> <tr> <td>4-3</td> <td>323</td> </tr> <tr> <td>3-2</td> <td>324</td> </tr> <tr> <td>2-1</td> <td>325</td> </tr> </tbody> </table>	Shift	Routine	1-2	320	2-3	321	3-4	322	4-3	323	3-2	324	2-1	325
Shift	Routine														
1-2	320														
2-3	321														
3-4	322														
4-3	323														
3-2	324														
2-1	325														
Main Controls —EPC solenoid, stuck or damaged hydraulically or mechanically —Valves, accumulators, seals stuck or damaged —Gaskets damaged —Solenoid screen (in valve body) blocked	—Inspect for damage, contamination and service as required. —Inspect for damage, contamination and service as required. —Inspect for damage and replace. —Clean or replace screen.														

⁴ Can be purchased as a separate item.



Technical Service Information

Timing Erratic

Possible Component	Reference/Action														
212 — ELECTRICAL ROUTINE															
Engine Concerns —TP, VSS, EDIS, MAF, EEC-IV microprocessor, vehicle wiring harness	—Run Self Test. —Refer to Powertrain Control/Emissions Diagnosis Manual ⁵ .														
Transmission Concerns — Shift solenoids, MCCC, OSS, MLPS, internal transmission harness, EEC-IV microprocessor	—Run Self Test. Perform pinpoint tests as outlined. Service as required.														
312 — HYDRAULIC/MECHANICAL ROUTINE															
Fluid —Improper level —Condition	—Adjust fluid to proper level. —Inspect as outlined under Fluid Condition Check.														
Main Control —Valves, accumulators, seal, gaskets damaged or stuck —Solenoid screen (in valve body) blocked	—Inspect for damage. Service as required. —Clean or replace screen.														
MCCC/Converter Clutch	—Refer to Hydraulic/Mechanical Routine 342, converter cycling.														
For Diagnosis related to a specific shift	—Refer to the appropriate shift routine(s) for additional diagnosis. <table border="1" data-bbox="839 909 1403 1098"><thead><tr><th>Shift</th><th>Routine</th></tr></thead><tbody><tr><td>1-2</td><td>320</td></tr><tr><td>2-3</td><td>321</td></tr><tr><td>3-4</td><td>322</td></tr><tr><td>4-3</td><td>323</td></tr><tr><td>3-2</td><td>324</td></tr><tr><td>2-1</td><td>325</td></tr></tbody></table>	Shift	Routine	1-2	320	2-3	321	3-4	322	4-3	323	3-2	324	2-1	325
Shift	Routine														
1-2	320														
2-3	321														
3-4	322														
4-3	323														
3-2	324														
2-1	325														

⁵ Can be purchased as a separate item.



Technical Service Information

Feel — Soft/Slipping

Possible Component	Reference/Action														
213 — ELECTRICAL ROUTINE															
Engine Concerns —MAF, EDIS, TP, EEC-IV microprocessor, vehicle wiring harness	—Run Self Test. —Refer to Powertrain Control/Emissions Diagnosis Manual ⁶ .														
Transmission Concerns —OSS, EPC, TOT, internal wiring harness, EEC-IV microprocessor	—Run Self Test. Perform pinpoint tests as outlined.														
313 — HYDRAULIC/MECHANICAL ROUTINE															
Fluid —Improper level —Condition	—Adjust fluid to proper level. —Inspect as outlined under Fluid Condition Check.														
Improper Pressures —Low line pressure —Low EPC pressure	—Check pressures at line and EPC taps. Refer to Hydraulic Pressure Chart for specifications. If pressures are low or all shifts are soft/slipping, go to Main Control. If pressures are OK and a specific shift is soft/slipping, refer to the appropriate routine(s) for additional diagnosis. <table border="1" data-bbox="888 871 1452 1060" style="margin: 10px auto;"> <thead> <tr> <th>Shift</th> <th>Routine</th> </tr> </thead> <tbody> <tr> <td>1-2</td> <td>320</td> </tr> <tr> <td>2-3</td> <td>321</td> </tr> <tr> <td>3-4</td> <td>322</td> </tr> <tr> <td>4-3</td> <td>323</td> </tr> <tr> <td>3-2</td> <td>324</td> </tr> <tr> <td>2-1</td> <td>325</td> </tr> </tbody> </table>	Shift	Routine	1-2	320	2-3	321	3-4	322	4-3	323	3-2	324	2-1	325
Shift	Routine														
1-2	320														
2-3	321														
3-4	322														
4-3	323														
3-2	324														
2-1	325														
Main Controls —1-2 Accumulator, 2-3 backout valve, main regulator valve, orifice control valve, overdrive servo regulator valve stuck or damaged —EPC solenoid stuck or damaged	—Inspect and service as required, —Inspect for damage and contamination, service as required.														



Technical Service Information

Feel — Harsh

Possible Component	Reference/Action														
214 — ELECTRICAL ROUTINE															
Engine Concerns —MAF, EDIS, TPS, EEC-IV microprocessor —Vehicle wiring harness	—Run Self Test. —Refer to Powertrain Control/Emissions Diagnosis Manual ⁷ for diagnosis.														
Transmission Concerns —OSS, EPC, TOT, internal wiring harness, EEC-IV microprocessor	—Run Self Test. Perform pinpoint tests as outlined.														
314 — HYDRAULIC/MECHANICAL ROUTINE															
Fluid —Improper level —Condition	—Adjust fluid to proper level. —Inspect as outlined under Fluid Condition Check.														
Improper Pressures —High line pressure, high EPC pressure	—Check pressures at line and EPC taps. Refer to Hydraulic Pressure Chart for specifications. If pressures are high or all shifts are harsh, go to Main Control. If pressures are OK and a specific shift is harsh, refer to the appropriate shift routine in the following chart: <table border="1" data-bbox="828 886 1392 1071"><thead><tr><th>Shift</th><th>Routine</th></tr></thead><tbody><tr><td>1-2</td><td>320</td></tr><tr><td>2-3</td><td>321</td></tr><tr><td>3-4</td><td>322</td></tr><tr><td>4-3</td><td>323</td></tr><tr><td>3-2</td><td>324</td></tr><tr><td>2-1</td><td>325</td></tr></tbody></table>	Shift	Routine	1-2	320	2-3	321	3-4	322	4-3	323	3-2	324	2-1	325
Shift	Routine														
1-2	320														
2-3	321														
3-4	322														
4-3	323														
3-2	324														
2-1	325														
Main Controls —1-2 Accumulator, 2-3 backout valve, main regulator valve, orifice control valve, Overdrive servo regulator valve; stuck or damaged —EPC solenoid stuck or damaged	—Inspect and service as required. —Inspect for damage and contamination, service as required.														

⁷ Can be purchased as a separate item.



Technical Service Information

No 1st Gear, Engages in Higher Gear

Possible Component	Reference/Action																								
215 — ELECTRICAL ROUTINE																									
Engine Concerns —TPS, EDIS, MAF, VSS, EEC-IV microprocessor, vehicle wiring harness	—Run Self Test. —Refer to Powertrain Control/Emissions Diagnosis Manual ⁸ . Service as required.																								
Transmission Concerns —Shift solenoids, OSS, MLPS	—Run Self Test. —Perform transmission pinpoint test as outlined. Service as required. Retest and road test.																								
315 — HYDRAULIC/MECHANICAL ROUTINE																									
Shift Linkage —Damaged or misadjusted	—Inspect and service as required. Adjust linkage as outlined. After servicing linkage, verify that the MLPS sensor is properly adjusted. Refer to Transmission, Assembly.																								
Improper Pressures —Low reverse clutch pressure, low reverse band pressure, low line pressure	—Check for which pressures are on and refer to Pressures Applied Chart and corresponding routines. Refer to the following electrical diagnostic routines: —324, 301 —325, 301 —323, 324, 325, 301 —324 —325 —323, 324, 325 —Refer to appropriate Mechanical Diagnosis.																								
<table border="1"> <thead> <tr> <th>Forward</th> <th>Intermediate</th> <th>Direct</th> </tr> </thead> <tbody> <tr> <td>Off</td> <td>Off</td> <td>X</td> </tr> <tr> <td>Off</td> <td>X</td> <td>Off</td> </tr> <tr> <td>Off</td> <td>X</td> <td>X</td> </tr> <tr> <td>X</td> <td>Off</td> <td>X</td> </tr> <tr> <td>X</td> <td>X</td> <td>Off</td> </tr> <tr> <td>X</td> <td>X</td> <td>X</td> </tr> <tr> <td>X</td> <td>Off</td> <td>Off</td> </tr> </tbody> </table>	Forward	Intermediate	Direct	Off	Off	X	Off	X	Off	Off	X	X	X	Off	X	X	X	Off	X	X	X	X	Off	Off	
Forward	Intermediate	Direct																							
Off	Off	X																							
Off	X	Off																							
Off	X	X																							
X	Off	X																							
X	X	Off																							
X	X	X																							
X	Off	Off																							
X = Pressures Applied CD8093-A																									
Mechanical —Bands, clutches or seals damaged or worn	—Refer to Transmission Disassembly and Assembly.																								

No Manual 1st Gear

Possible Component	Reference/Action
216 — ELECTRICAL ROUTINE	
Engine Concerns —TP, MAF, EDIS, VSS, EEC-IV microprocessor, vehicle wiring harness	—Run Self Test. —Refer to Powertrain Control/Emissions Diagnosis Manual ⁸ . Service as required.
Transmission Concerns —Shift solenoids, OSS, MLPS	—Run Self Test. —Perform transmission pinpoint test as outlined. Service as required. Retest and road test.
316 — HYDRAULIC/MECHANICAL ROUTINE	
Shift Linkage —Damaged or misadjusted	—Inspect and service as required. Adjust linkage as outlined. After servicing linkage, verify that the MLPS sensor is properly adjusted. Refer to Transmission, Assembly.
Improper Pressures —Low reverse clutch pressure —Low reverse band pressure —Low line pressure —Low EPC pressure	—Check pressure at line and EPC pressure taps. Refer to Hydraulic Pressure Chart for specifications. If pressures are low, check the following possible components: oil filter and seal assembly, main control and reverse servo assembly.
Oil Filter and Seal Assembly —Plugged or damaged	—Replace filter and seal assembly.
Main Controls —No. 6 shuttle ball, manual valve, main regulator valve, low servo modulator valve; stuck or damaged —Bolts not tightened to specification. —Gaskets damaged	—Inspect for damage, service as required. —Retighten bolts to specification. —Inspect for damage and replace.
Low Reverse Servo —Seals damaged (piston and cover) —Servo cover retaining ring assembled incorrectly —Anchor pins damaged	—Inspect for damage. Service as required.



Technical Service Information

Shift Concern: 1-2 Shift

Possible Component	Reference/Action
220 — ELECTRICAL ROUTINE	
Engine Concerns —TP, MAF, EDIS, VSS, EEC-IV microprocessor, vehicle wiring harness	—Run Self Test. —Refer to Powertrain Control/Emissions Diagnosis Manual ¹⁰ . Service as required.
Transmission Concerns —Shift solenoids, OSS, MLPS	—Run Self Test. —Perform transmission pinpoint test as outlined. Service as required. Retest and road test.
320 — HYDRAULIC/MECHANICAL ROUTINE	
Shift Linkage —Damaged or misadjusted	—Inspect and service as required. Adjust linkage as outlined. After servicing linkage, verify that the MLPS sensor is properly adjusted. Refer to Transmission, Assembly.
Improper Pressures —Intermediate clutch pressure —Line pressure	—Check pressure at line and intermediate clutch taps. Refer to Hydraulic Pressure Chart for specifications. If not OK, check the Main Control.
Main Control —1-2 Shift valve, 1-2 accumulator stuck or damaged —Bolts not tightened to specification. —SS-1 Malfunction —Gasket leaks —No. 8 ball not seating	—Inspect and service as required. —Retighten bolts to specification. —Activate solenoid using transmission tester. If solenoid operation cannot be felt when placing hand on solenoid, replace solenoid. —Inspect O-rings for damage; service as required. —Inspect and replace. —Inspect and service as required.
Pump —Porosity/cross leak —Gasket damaged —Ball damaged	—Inspect and replace as required. —Inspect for damage, replace as required. —Inspect for damage or missing ball, replace pump assembly.
Intermediate Clutch Assembly —Seals damaged —Piston damaged —Friction damaged or worn	—Inspect for damage, replace as required.
Intermediate One-Way Clutch Assembly —Not holding or damaged	—Inspect for damage, replace as required.
Low One-Way Clutch Assembly —Not overrunning or damaged	—Inspect for damage, replace as required.

¹⁰ Can be purchased as a separate item.



Technical Service Information

Shift Concern: 2-3 Shift

Possible Component	Reference/Action
221 — ELECTRICAL ROUTINE	
Engine Concerns —TPS, MAF, EDIS, VSS, EEC-IV microprocessor, vehicle wiring harness	—Run Self Test. —Refer to Powertrain Control/Emissions Diagnosis Manual ¹¹ . Service as required.
Transmission Concerns —Shift solenoids, OSS, MLPS	—Run Self Test. —Perform transmission pinpoint test as outlined. Service as required. Retest and road test.
321 — HYDRAULIC/MECHANICAL ROUTINE	
Shift Linkage —Damaged or misadjusted	—Inspect and service as required. Adjust linkage as outlined. After servicing linkage, verify that the MLPS sensor is properly adjusted. Refer to Transmission, Assembly.
Improper Pressures —Direct clutch pressure	—Check pressure at direct clutch and line taps. Refer to Hydraulic Pressure Chart for specifications. If not OK, check the main control.
Main Control —2-3 Shift valve, check ball No. 1 or No. 3, solenoid pressure regulator valve, 2-3 backout valve, 2-3 modulator valve, orifice control valve — stuck or damaged —Bolts not tightened to specification. —SS-2 Malfunction —Gasket leaks —Output shaft seals damaged —Cup plug leaking or missing —2-3 Accumulator damaged or stuck —Solenoid screen (in main control) blocked	—Inspect and service as required. —Retighten to specification. —Activate solenoid using transmission tester. If solenoid operation cannot be felt when placing hand on solenoid replace solenoid. —Inspect O-rings for damage and service as required. —Inspect and replace. —Inspect and replace as required. —Inspect piston seal and bore for damage. Service as required. —Clean or replace.
Intermediate One-Way Clutch Assembly —Not overrunning or damaged	—Inspect for damage, replace as required.
Output Shaft —Seal rings —Cup plug damaged or missing	—Inspect for damage, service as required.
Direct Clutch Assembly —Seals —Piston —Friction damaged or worn —Check ball not seating —Return spring assembly	—Inspect for damage, replace as required.
Case —Output shaft rear seal	—Inspect for damage, replace case if damaged.



Technical Service Information

Shift Concern: 3-4 Shift

Possible Component	Reference/Action
222 — ELECTRICAL ROUTINE	
Engine Concerns —TPS, MAF, EDIS, VSS, EEC-IV microprocessor or vehicle wiring harness	—Run Self Test. —Refer to Powertrain Control/Emissions Diagnosis Manual ¹² . Service as required.
Transmission Concerns —Shift solenoids, OSS, MLPS	—Run Self Test. —Perform transmission pinpoint tests as outlined. Service as required. Retest and road test.
322 — HYDRAULIC/MECHANICAL ROUTINE	
Shift Linkage —Damaged or misadjusted	—Inspect and service as required. Adjust linkage as outlined. After servicing linkage, verify that the MLPS sensor is properly adjusted. Refer to Transmission, Assembly.
Improper Pressures —Forward clutch —Direct clutch —Line	—Check line, direct, forward clutch pressure at appropriate taps. Refer to Hydraulic Pressure Chart for specifications. If pressures are out of specification, check Main Control.
Main Control —3-4 Shift Valve, Solenoid pressure regulator valve, OD servo regulator, 3-4 capacity modulator valve, 2-3 backout valve, orifice control valve, 1-2 and 2-3 shift valves stuck or damaged —Bolts not tightened to specification. —SS-1/SS-2 malfunction —Gasket leaks —Servo cover, seal, rod and piston cushion spring damaged —No's 1, 2, 4 and 7 check balls —Solenoid screen (in main control) blocked	—Inspect and service as required. —Retighten bolts to specification. —Activate solenoid using transmission tester. If solenoid operation cannot be felt when placing hand on solenoid, replace solenoid. —Inspect O-rings for damage and service as required. —Inspect and replace as required. —Inspect for damage and replace as required. —Inspect for damage and replace as required. —Inspect for damage and replace as required. —Clean or replace.
Pump —Porosity/cross leak —Gasket damaged —Check ball damaged, not seating	—Inspect pump for damage and service or replace as required.
OD Band —OD band and reverse clutch drum assembly damaged, worn or misassembled —Intermediate one-way clutch assembly damaged	—Inspect for damage and service or replace as required.
Forward Clutch Assembly —Seals —Piston —Friction damaged or worn —Check ball not operating	—Inspect for damage and replace as required.
Input Shaft —Seals	—Inspect for damage and service or replace as required.



Technical Service Information

Shift Concern: 4-3 Shift

Possible Component	Reference/Action
223 — ELECTRICAL ROUTINE	
Engine Concerns —TPS, MAF, EDIS, VSS, EEC-IV microprocessor, vehicle wiring harness	—Run Self Test. —Refer to Powertrain Control/Emissions Diagnosis Manual ¹³ for diagnosis. Service as required.
Transmission Concerns —Shift solenoids, OSS, MLPS	—Run Self Test. —Perform transmission pinpoint tests. Service as required. Retest and road test.
323 — HYDRAULIC/MECHANICAL ROUTINE	
Improper Pressures —Forward clutch, line	—Check line and forward clutch at pressure tap. —Refer to Hydraulic Pressure Chart for specification. If out of specification, check main control.
Main Control —3-4 shift valve, solenoid pressure regulator valve, overdrive servo regulator, 3-4 capacity modulator, orifice control valve, 2-3 backout valve, 1-2, 2-3 shift valves stuck or damaged —Check balls No. 1, No. 2, No. 7 —Bolts not tightened to specification —SS-1 malfunction —Gasket leaks —Overdrive servo, seal, rod damaged —Solenoid screen (in main control) blocked	—Inspect; service as required —Inspect for proper seating; service as required. —Retighten bolts to 8-10 N·m (7.1-8.8 Lb·In). —Activate solenoid using transmission tester. If solenoid operation cannot be felt when placing hand on solenoid, replace solenoid. —Inspect O-rings for damage; service as required. —Inspect and replace. —Inspect for damage; service as required. —Clean or replace.
Pump —Porosity/cross leak, Gasket damaged Seal rings damaged, missing or leaking ball	—Inspect pump for damage; service or replace pump as required.
Overdrive Band —Overdrive band and reverse clutch assembly damaged/worn/misassembled —Intermediate one-way clutch assembly damaged	—Inspect for damage; replace as required. —Inspect for damage; service as required.
Forward Clutch Assembly —Seals —Piston —Friction damaged, worn —Check ball not functioning —Forward clutch piston and return spring damaged	—Inspect for damage; replace as required. —Inspect for damage; replace as required. —Inspect for damage; replace as required. —Inspect for damage; replace as required. —Inspect for damage; service as required.
Input Shaft —Seals	—Inspect for damage; replace as required.

¹³ Can be purchased as a separate item.



Technical Service Information

Shift Concern: 3-2 Shift

Possible Component	Reference/Action
224 — ELECTRICAL ROUTINE	
Engine Concerns —TPS, MAF, EDIS, VSS, EEC-IV microprocessor, vehicle wiring harness	—Run Self Test. —Refer to Powertrain Control/Emissions Diagnosis Manual ¹⁴ for diagnosis. Service as required.
Transmission Concerns —Shift solenoids, OSS, MLPS	—Run Self Test. —Perform transmission pinpoint tests. Service as required. Retest and road test.
324 — HYDRAULIC/MECHANICAL ROUTINE	
Improper Pressures —Direct clutch	—Check pressure at direct clutch tap. Refer to Pressure Chart for specification; if not within specification, check main control.
Main Control —2-3 shift valve stuck or damaged —Check balls —Bolts not tightened to specification —SS-2 malfunction —Gasket leaks	—Inspect; service as required —Inspect; service as required. —Retighten bolts to specification. —Activate solenoid using transmission tester. If solenoid operation cannot be felt when placing hand on solenoid, replace solenoid. —Inspect O-rings for damage; service as required. —Inspect and replace.
Intermediate One-Way Clutch not Holding —Damaged	—Inspect for damage; replace as required.
Direct Clutch Assembly —Seals —Piston —Friction damaged, worn —Check ball not functioning	—Inspect for damage; replace as required. —Inspect for damage; replace as required. —Inspect for damage; replace as required. —Inspect for damage; replace as required.

¹⁴ Can be purchased as a separate item.



Technical Service Information

Shift Concern: 2-1 Shift (Automatic)

Possible Component	Reference/Action
225 — ELECTRICAL ROUTINE	
Engine Concerns —TPS, MAF, EDIS, VSS, EEC-IV microprocessor, vehicle wiring harness	—Run Self Test. —Refer to Powertrain Control/Emissions Diagnosis Manual ¹⁵ for diagnosis. Service as required.
Transmission Concerns —Shift solenoids, OSS, MLPS	—Run Self Test. —Perform transmission pinpoint tests. Service as required. Retest and road test.
325 — HYDRAULIC/MECHANICAL ROUTINE	
Improper Pressures —Intermediate clutch	—Check pressure at intermediate clutch tap. Refer to Hydraulic Pressure Chart for specifications. If not within specifications, check Main Control and Pump.
Main Control —1-2 shift valve, 1-2 accumulator solenoid pressure regulator valve —Bolts not tightened to specification —SS-1 malfunction —Gasket leaks	—Inspect; service as required —Retighten bolts to specification. —Activate solenoid using transmission tester. If solenoid operation cannot be felt when placing hand on solenoid, replace solenoid. —Inspect O-rings for damage; service as required. —Inspect and replace.
Pump —Gaskets damaged —Porosity/cross leak	—Inspect for damage; replace as required. —Inspect for leak/porosity; replace as required.
Intermediate Clutch Assembly —Piston —Friction damaged, worn —End clearance improper	—Inspect for damage; replace as required. —Inspect for damage; replace as required. —Inspect and correct as outlined under Transmission, Assembly
Intermediate One-Way Clutch —Damaged	—Inspect for damage; replace as required.
Low One-Way Clutch —Damaged	—Inspect for damage; replace as required.

¹⁵ Can be purchased as a separate item.



Technical Service Information

Converter: No Apply

Possible Component	Reference / Action
240 — ELECTRICAL ROUTINE	
Engine Concerns —BOO, ECT, TPS, EDIS, EEC-IV microprocessor, vehicle harness	—Run Self Test. —Refer to Powertrain Control / Emissions Diagnosis Manual ¹⁶ for diagnosis.
Transmission Concerns —Vehicle harnesses, TOT, MCCC, MLPS, OSS	—Refer to pinpoint tests.
340 — HYDRAULIC / MECHANICAL ROUTINE	
Shift Linkage —Damaged, misadjusted	—Inspect and service as required. Adjust linkage as outlined. After servicing linkage, verify that the MLPS sensor is properly adjusted. Refer to Transmission, Assembly.
Improper Pressures —Low line pressure, low EPC	—Check pressure at line and EPC taps. Refer to Hydraulic Pressure Chart for specifications. —If low - check EPC, main regulator valve. If within specification, check main control.
Main Controls —Solenoid pressure regulator valve, manual valve, bypass clutch control valve and plunger, converter pressure limit valve, drain back valve stuck, damaged —Bolts not tightened to specification —Solenoid screen (in valve body) blocked —MCCC solenoid malfunction —Gaskets	—Inspect and service as required. —Retighten bolts to specification. —Clean or replace screen. —Activate solenoid using transmission tester. If solenoid operation cannot be felt when placing hand on solenoid, replace solenoid. —Inspect O-rings for damage; service as required. —Inspect gasket for damage and replace.
Pump Assembly —Bolts not tightened to specification. —Porosity / cross leaks, balls leaking —Gaskets damaged	—Retighten bolts to specification. —Inspect for porosity / leaks, ball missing, replace pump as required. —Inspect and replace gaskets.
Input Shaft —Seals	—Inspect for damage; replace as necessary.
Converter —Leakage, friction material, internal seals	—Inspect and replace as required.



Technical Service Information

Converter: Always Applied/Stalls Vehicle

Possible Component	Reference/Action
241 — ELECTRICAL ROUTINE	
Engine Concerns —ECT, EEC-IV microprocessor	—Run Self Test. —Refer to Powertrain Control/Emissions Diagnosis Manual ¹⁷ for diagnosis.
Transmission Concerns —Vehicle harness, TOT, MCCC	—Refer to pinpoint tests.
341 — HYDRAULIC/MECHANICAL ROUTINE	
Main Controls —Drain back valve, bypass clutch and plunger stuck or damaged —Bolts not tightened to specification —MCCC solenoid malfunction —No. 7 ball improper seating —Gaskets damaged	—Inspect and service as required. —Retighten bolts to 8-10 N-m (7 1-88 Lb-In). —Activate solenoid using transmission tester. If solenoid operation cannot be felt when placing hand on solenoid, replace solenoid. —Inspect O-rings for damage; service as required. —Service as required. —Inspect for damage and replace.
Pump Assembly —Bolts not tightened to specification —Ball missing, leaking, porosity/cross leaks —Gaskets damaged	—Retighten bolts to 20-26 N-m (15-19 Lb-Ft). —Inspect for porosity/leaks, balls missing, replace pump as required. —Inspect and replace.
Input Shaft —Seals	—Inspect for damage; replace as necessary.
Converter —End clearance (No) —Piston plate damage/stuck to cover	—Inspect and replace as required. —If cover is heat stained, replace converter.

¹⁷ Can be purchased as a separate item.



Technical Service Information

Converter: Cycling/Shudder/Chatter

Possible Component	Reference/Action
242 — ELECTRICAL ROUTINE	
Engine Concerns —BOO, TPS, EDIS, EEC-IV microprocessor, vehicle harness	—Run Self Test. —Refer to Powertrain Control/Emissions Diagnosis Manual ¹⁸ for diagnosis.
Transmission Concerns —MCCC, MLPS, OSS	—Refer to pinpoint tests.
342 — HYDRAULIC/MECHANICAL ROUTINE	
Fluid Condition	—Inspect fluid condition. If burnt, drain fluid and converter. Replace fluid and filter assembly. Bring vehicle to normal operating temperature. Perform drive cycle as outlined. Perform Self Test. If condition still exists, continue diagnostics.
Main Controls —Solenoid pressure regulator valve, No. 7 check ball bypass clutch control valve and plunger, converter pressure limit valve stuck or damaged —Bolts not tightened to specification —Solenoid screen (in valve body) blocked —MCCC solenoid malfunction —Gaskets damaged	—Inspect and service as required. —Retighten bolts to specification. —Clean or replace screen. —Activate solenoid using transmission tester. If solenoid operation cannot be felt when placing hand on solenoid, replace solenoid. —Inspect O-rings for damage; service as required. —Inspect for damage and replace.
Pump Assembly —Bolts not tightened to specification —Porosity/cross leaks, balls missing/leaking —Gaskets damaged	—Retighten bolts to specification. —Inspect for porosity/leaks, balls missing, replace pump as required. —Inspect for damage and replace.
Input Shaft —Seals	—Inspect for damage; replace as necessary.
Converter —End clearance (excessive)	—Inspect and replace as required.

18 Can be purchased as a separate item.



Technical Service Information

No Engine Braking in 2nd Gear, Manual 1st Position

Possible Component	Reference / Action
250 — ELECTRICAL ROUTINE	
No Electrical Concerns	
350 — HYDRAULIC/MECHANICAL ROUTINE	
Shift Linkage —Damaged or misadjusted	—Inspect and service as required. Adjust linkage as outlined. After servicing linkage, verify that the MLPS sensor is properly adjusted. Refer to Transmission, Assembly.
Main Controls —3-4 shift valve, 1-2 and 2-3 shift valve, gaskets, orifice control valve, 3-4 capacity modulator valve, stuck or damaged —Overdrive servo assembly damaged	—Inspect, clean or service as required. —Inspect cover, piston and seal for damage. Service as required.
Overdrive —Overdrive band, reverse clutch drum assembly worn or damaged —Intermediate one-way clutch assembly damaged	—Inspect, service and replace as required. —Inspect and service as required.

Shift Efforts High

Possible Component	Reference / Action
251 — ELECTRICAL ROUTINE	
No Electrical Concerns	
351 — HYDRAULIC/MECHANICAL ROUTINE	
Shift Linkage —Damaged or misadjusted	—Inspect and service as required. Adjust linkage as outlined. After servicing linkage, verify that the MLPS sensor is properly adjusted. Refer to Transmission, Assembly.
Manual Lever —Retaining pin damaged, nut loose, detent spring-bent damaged or park mechanism damaged	—Inspect and service as required.
Main Control —Manual valve stuck —Bolts not tightened to specification	—Inspect and service or replace as necessary. —Retighten bolts to specification.
Brake Shift Interlock	—Refer to Section 07-05.



Technical Service Information

External Leaks

Possible Component	Reference/Action
252 — ELECTRICAL ROUTINE	
Engine Concerns: — Vehicle Speed Sensor Sensor, seals	—Inspect and service as required.
Transmission Concerns Transmission Connector —OSS seals or MLPS sensor	—Inspect and service as required.
352 — HYDRAULIC/MECHANICAL ROUTINE	
Seals/Gaskets —Converter, pump, pan, extension housing - gasket/seal, manual lever, fluid level indicator	—Locate source and service as required.
Other —Cooler fitting, pressure taps, converter drain plug, band anchor pins, cooler lines, case porosity, case cracked —Vent blocked or damaged	—Locate source and service as required. —Check vent for damage or blockage; service as required.

Poor Vehicle Acceleration

Possible Component	Reference/Action
253 — ELECTRICAL ROUTINE	
Engine Concerns	—Refer to Powertrain Control/Emissions Diagnosis Manual ¹⁹ for diagnosis.
Transmission Concerns —MCCC, TOT, TPS, MLPS, EEC-IV microprocessor, vehicle wiring harness and internal transmission harness	—Run Self Test. —Refer to Electrical Diagnostic Routine 241.
353 — HYDRAULIC/MECHANICAL ROUTINE	
Shift Linkage —Damaged or misadjusted	—Inspect and service as required. Adjust linkage as outlined. After servicing linkage, verify that the MLPS sensor is properly adjusted. Refer to Transmission, Assembly.
Verify proper shift scheduling and engagements	—Go to the appropriate Diagnostic Routines.
Converter clutch always applied	—Go to Hydraulic/Mechanical Routine 341.
Converter One-Way Clutch —Damaged	—Replace converter if damaged.



Technical Service Information

Noise/Vibration - Forward/Reverse

Possible Component	Reference/Action																
254 — ELECTRICAL ROUTINE																	
No Electrical Concerns																	
354 — HYDRAULIC/MECHANICAL ROUTINE																	
For Noises/Vibrations That Change With Engine Speed: —Converter components —Fluid level (low) pump cavitation —Pump assembly —Engine drive accessories —Cooler lines grounding out —Flywheel	—Locate source of disturbance and service as required.																
For Noises/Vibrations That Change With Vehicle Speed: —Engine mounts —loose or damaged —Driveline concerns u-joints rear axle suspension modifications —1st Gear low one-way clutch friction elements —2nd Gear intermediate one-way clutch intermediate clutch piston bleed hole out of 12 O'clock position, friction elements —3rd Gear converter anti clunk spring friction elements —4th Gear gear set friction elements converter —Reverse gear set friction element —Output Shaft Splines worn or damaged	—Locate source of disturbance and service as required. —For specific shifts or converter concern, refer to appropriate routines: <table border="1" data-bbox="848 1087 1415 1297"> <thead> <tr> <th>Shift</th> <th>Routine</th> </tr> </thead> <tbody> <tr> <td>1-2</td> <td>320</td> </tr> <tr> <td>2-3</td> <td>321</td> </tr> <tr> <td>3-4</td> <td>322</td> </tr> <tr> <td>4-3</td> <td>323</td> </tr> <tr> <td>3-2</td> <td>324</td> </tr> <tr> <td>2-1</td> <td>325</td> </tr> <tr> <td>Converter Cycling</td> <td>242/342</td> </tr> </tbody> </table>	Shift	Routine	1-2	320	2-3	321	3-4	322	4-3	323	3-2	324	2-1	325	Converter Cycling	242/342
Shift	Routine																
1-2	320																
2-3	321																
3-4	322																
4-3	323																
3-2	324																
2-1	325																
Converter Cycling	242/342																
Other Noises/Vibrations: —Main Controls valve resonance —Shift Cable vibration, grounding cooler lines grounding	—Locate source of disturbance and service as required.																



Technical Service Information

Engine Will Not Crank

Possible Component	Reference / Action
255 — ELECTRICAL ROUTINE	
Engine Concerns	—Refer to Powertrain Control / Emissions Diagnosis Manual ²⁰ for diagnostics of no crank concerns.
Transmission Concerns —MLPS misadjusted or damaged	—Perform diagnostics using MLPS tester. Service and adjust as required. Refer to Transmission Assembly.
355 — HYDRAULIC/MECHANICAL ROUTINE	
Shift Linkage —Damaged or misadjusted	—Inspect and service as required. Adjust linkage as outlined. After servicing linkage, verify that the MLPS sensor is properly adjusted. Refer to Transmission, Assembly.

No Park Range

Possible Component	Reference / Action
256 — ELECTRICAL ROUTINE	
No Electrical Concerns	
356 — HYDRAULIC/MECHANICAL ROUTINE	
Shift Linkage —Damaged or misadjusted	—Inspect and service as required. Adjust linkage as outlined. After servicing linkage, verify that the MLPS sensor is properly adjusted. Refer to Transmission, Assembly.
Park Mechanism —Output shaft ring, park brake pawl, parking pawl return spring, park rod guide cup, parking pawl shaft, parking pawl actuating rod, manual lever, manual lever detent spring - damaged	—Inspect and service as required.



Technical Service Information

Transmission Overheating

Possible Component	Reference/Action
257 — ELECTRICAL ROUTINE	
Refer to Electrical Routine 240, Converter —No Apply	—Refer to Electrical Routine 240, Converter - No Apply
357 — HYDRAULIC/MECHANICAL ROUTINE	
Fluid —Improper level —Condition	—Adjust fluid to proper level. —Inspect as outlined under Fluid Condition Check.
Cooler Lines —Damaged, blocked or reversed	—Inspect and service as required.
Auxiliary Cooler —Damaged, blocked or restricted, improperly installed	—Inspect and service as required.
Vehicle Concerns Causing Engine Overheating	—Refer to Section 03-03
Main Control —Drain back valve, bypass clutch control valve, converter limit valve stuck or damaged	—Inspect and service as required.
Converter —No Apply	—Refer to Hydraulic/Mechanical Routine 340, Transmission Overheating.

NOTE: Vehicle harness must be installed at transmission connector to verify these pressures.

CAUTION: Do not install Transmission Tester when verifying these pressures.

401 — Diagnostic Pressure Chart

GEAR	Pressures At Idle				
	EPC (TV) 88	LINE	FORWARD CLUTCH	INTERMEDIATE CLUTCH	DIRECT CLUTCH
1M 1D	0-62 kPa (0-9 psi)	345-517 kPa (50-75 psi)	310-517 kPa (45-75 psi)	0-34 kPa (0-5 psi)	0-34 kPa (0-5 psi)
2M 2D	0-62 kPa (0-9 psi)	345-517 kPa (50-75 psi)	310-517 kPa (45-75 psi)	310-517 kPa (45-75 psi)	0-34 kPa (0-5 psi)
3	0-62 kPa (0-9 psi)	345-517 kPa (50-75 psi)	310-517 kPa (45-75 psi)	310-517 kPa (45-75 psi)	310-517 kPa (45-75 psi)
4	0-62 kPa (0-9 psi)	345-517 kPa (50-75 psi)	0-34 kPa (0-5 psi)	310-517 kPa (45-75 psi)	310-517 kPa (45-75 psi)
R	0-62 kPa (0-9 psi)	552-827 kPa (80-120 psi)	0-34 kPa (0-5 psi)	0-34 kPa (0-5 psi)	0-34 kPa (0-5 psi)
P	0-62 kPa (0-9 psi)	345-517 kPa (50-75 psi)	0-34 kPa (0-5 psi)	0-34 kPa (0-5 psi)	0-34 kPa (0-5 psi)
N	0-62 kPa (0-9 psi)	345-517 kPa (50-75 psi)	0-34 kPa (0-5 psi)	0-34 kPa (0-5 psi)	0-34 kPa (0-5 psi)



Technical Service Information

Pressures at Wide Open Throttle (WOT) Stall

GEAR	EPC (TV)	LINE	FORWARD CLUTCH	INTERMEDIATE CLUTCH	DIRECT CLUTCH
1M 1D	573-642 kPa (83-93 psi)	1104-1447 kPa (160-210 psi)	1035-1447 kPa (150-210 psi)	0-34 kPa (0-5 psi)	0-34 kPa (0-5 psi)
R	573-642 kPa (83-93 psi)	1517-1930 kPa (220-280 psi)	0-34 kPa (0-5 psi)	0-34 kPa (0-5 psi)	0-34 kPa (0-5 psi)

NOTE: Pressures may vary with model.

REMOVAL AND INSTALLATION

Fluid Cooler Lines

Tube Fittings

When fluid leakage is found at the oil cooler, the cooler must be replaced. Refer to Group O3 for coolant replacement procedure.

When one or more of the fluid cooler steel tubes must be replaced, each replacement tube must be fabricated from the same size steel tubing as the original line.

Using the old tube as a guide, bend the new tube as required. Add the necessary fittings, and install the tube.

After the fittings have been tightened to specification, add fluid as needed and check for fluid leaks.

NOTE: Some vehicles come equipped with double flare threaded fittings. For these vehicles, service as outlined under threaded fittings.

DISASSEMBLY AND ASSEMBLY

NOTE: Before beginning Disassembly, perform / inspect the following:

- The transmission service area should be kept clean, well organized and supplied with clean lint-free shop cloths.
- Thorough cleaning of the transmission exterior will reduce the possibility that damaging contaminants might enter the subassemblies during disassembly and assembly.

- If the transmission is being removed for major overhaul, it is important to completely clean all transmission components, including converter, cooler, cooler lines, main control valve body, all clutches and all check balls after any transmission servicing that generates contamination. These contaminants are a major cause for recurring transmission troubles and must be removed from the system before the transmission is put back into service.
The cleaning of debris from the direct clutch check ball is often omitted. This omission can lead to a repeat servicing of the transmission.

- Debris that collects and builds up in the corners of the stamped clutches must be removed.
- The magnet should be removed from oil pan and wiped clean along with the pan.
- Whenever a seal is removed from a piston, shaft or servo, note the type of seal and when applicable, the direction of the sealing lip.

NOTE: Before beginning Assembly, perform / inspect the following:

- All fasteners must be tightened to the torque indicated in the text. In addition to appearing in the text, the necessary torques can be found under Specifications.
- When building up subassemblies, each component part should be lubricated with clean transmission fluid. It is also good practice to lubricate the subassemblies as they are installed in the case.
- Needle bearings, thrust washers and seals should be lightly coated with petroleum jelly during subassembly build up or transmission assembly.
- Many components and surfaces in the transmission are precision machined. Careful handling during disassembly, cleaning, inspection and assembly can prevent unnecessary damage to machined surfaces.

When building up subassemblies and assembling the transmission, ALWAYS use new gaskets and seals.

Transmission Disassembly

1. Mount transmission in Bench Mounted Holding Fixture T57L-500-B or equivalent.

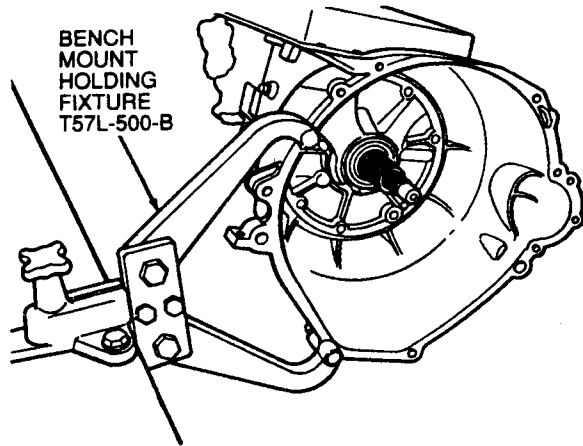

2. Remove fourteen 10mm oil pan retaining bolts, oil pan and pan gasket. Discard gasket.

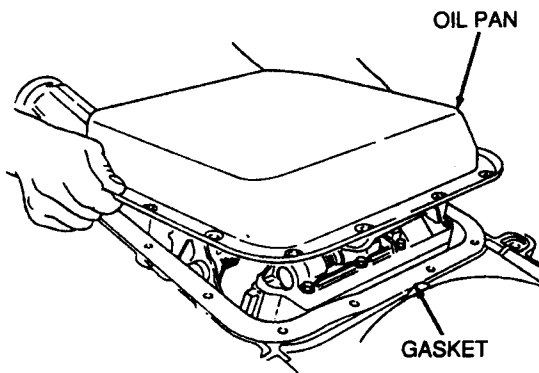

3. Remove oil pan magnet. Clean pan and magnet.

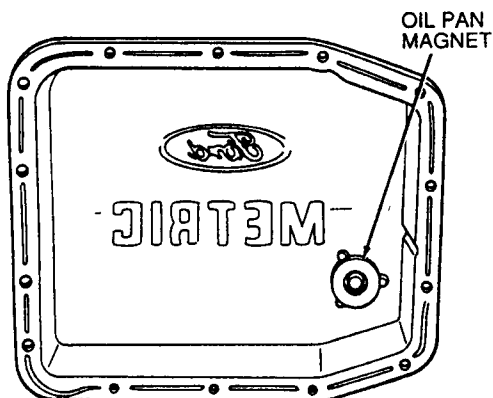

D10254-A

4. Using both hands, remove filter by pulling upward.

NOTE: Always use a new filter and grommet. Never attempt to clean or reuse a dirty filter.

NOTE: If grommet remains in main control bore, use a small screwdriver to pry it out. Take care not to damage main control bore.

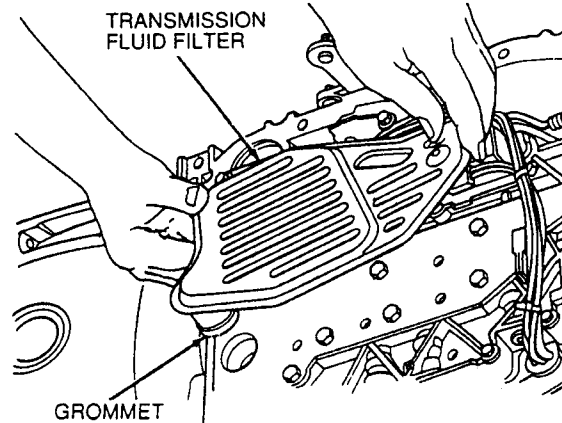

5. Grasp connector at each solenoid or sensor and pull straight out to disconnect.

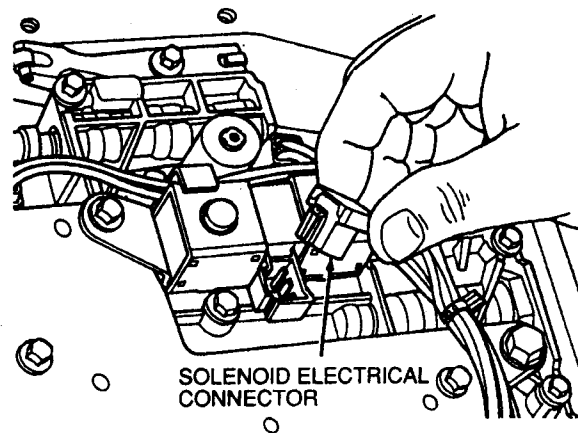

CAUTION: Do not pull on wires. If required, carefully pry up on locking tab and disconnect the connector.

6. Remove 8mm bolt attaching output shaft speed (OSS) sensor to transmission case and remove OSS.

NOTE: Removal of the OSS at this time will prevent sensor damage when removing the output shaft assembly.

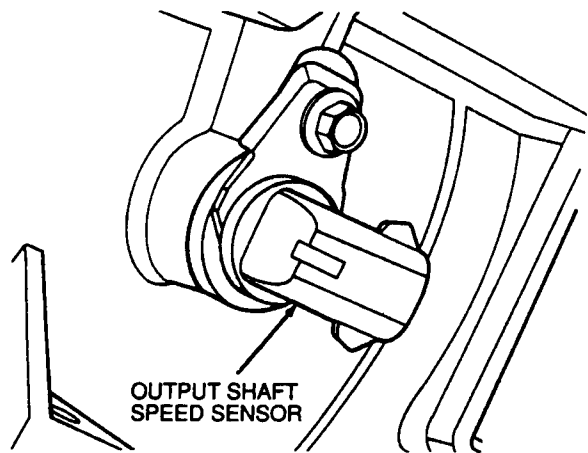

7. Remove two 8mm bolts retaining manual lever position sensor (MLPS) to case. Remove MLPS from manual shaft.

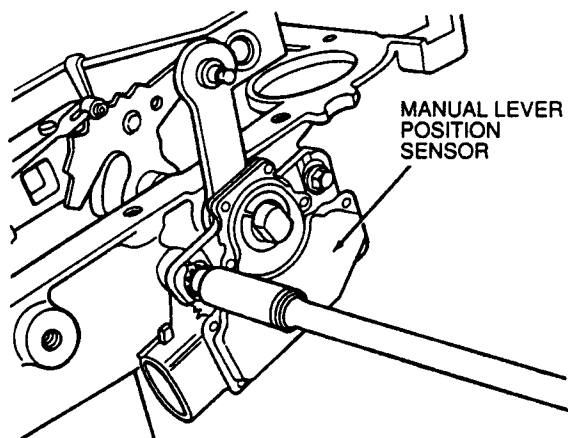

8. Remove one 8mm bolt retaining manual lever detent spring and roller assembly to the valve body.

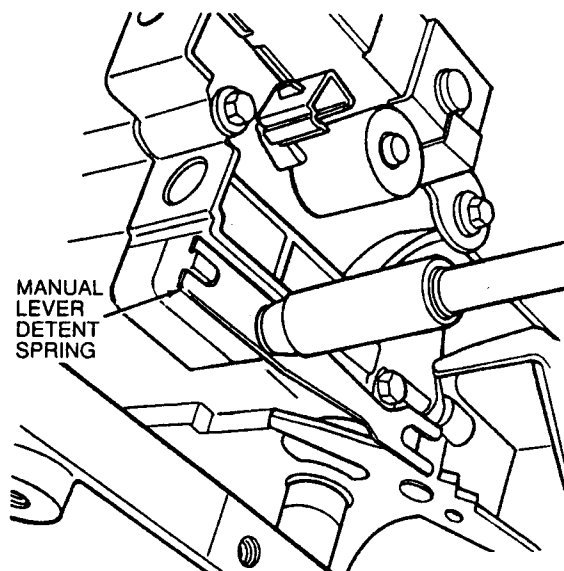

9. Remove remaining twenty-four 8mm valve body-to-case retaining bolts, the valve body assembly and the valve-to-body gasket.

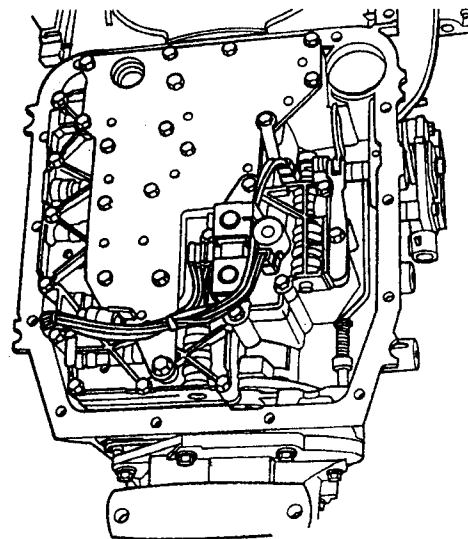

10. Remove manual shaft roll pin.

NOTE: Use a shop cloth to protect pan-to-case surface.

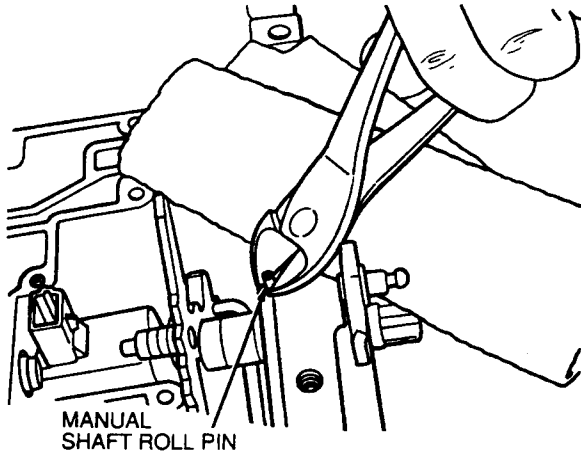

11. Using a 13/16-inch open-end wrench on the inner nut and a 12mm wrench on the manual shaft flats, loosen the inner nut.

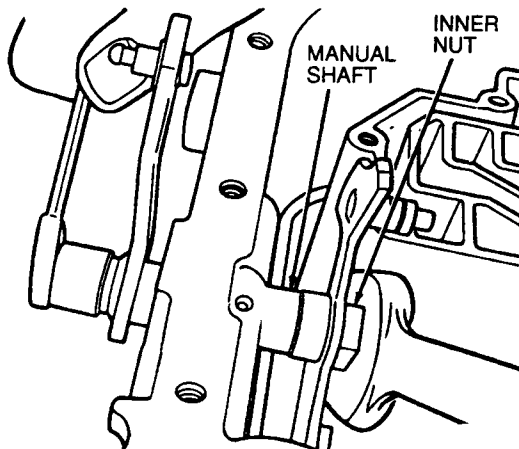

Slide manual shaft partially out of the case to complete removal of the inner nut from shaft.

12. Using a screwdriver on the manual lever shaft seal lower edge, carefully pry seal out of case bore.

NOTE: Do not damage bore with the prying tool.

13. Lift rooster comb and park pawl actuating rod out of the case.

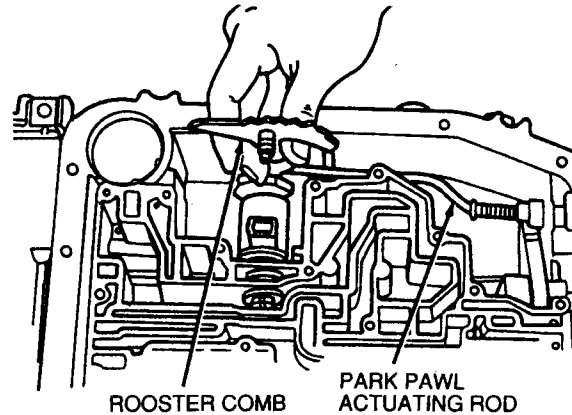

14. Remove electronic pressure control (EPC) solenoid by sliding it out of the case bore.

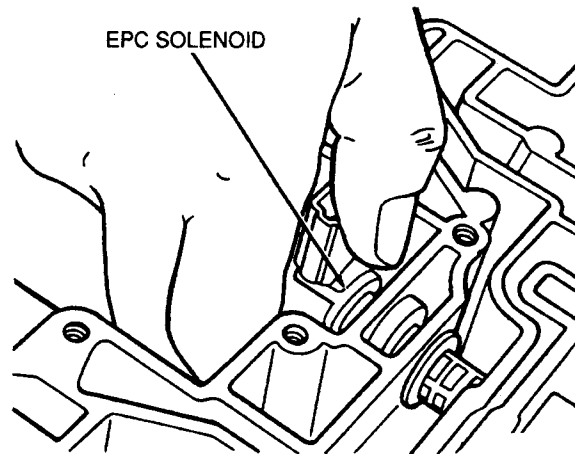

19. Remove piston assembly. Remove spring.

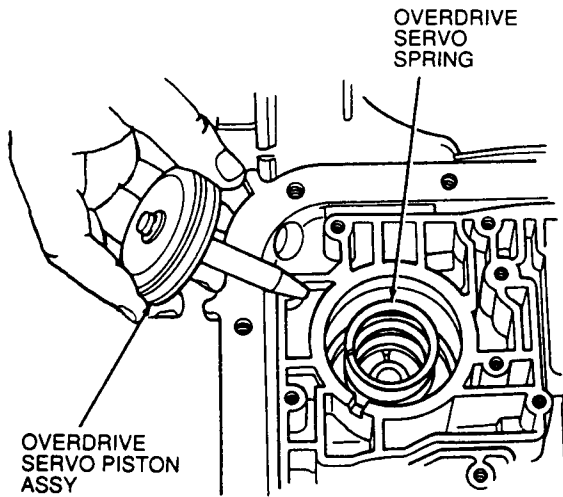

NOTE: The length of the rod attached to the piston may vary in length from transmission to transmission. Therefore, they should not be installed in any transmission other than the transmission they were removed from.

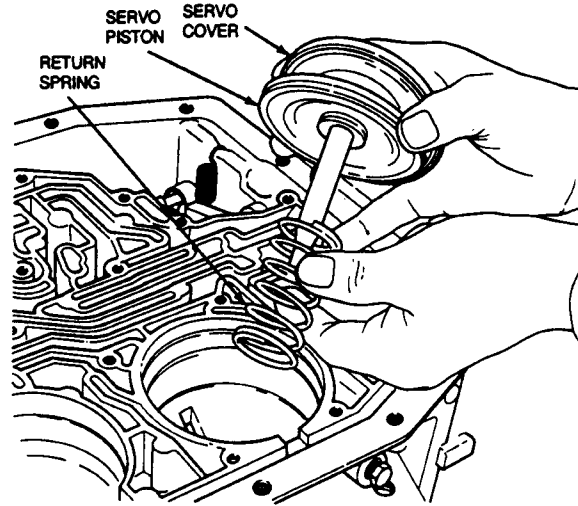

Low/Reverse Servo Removal

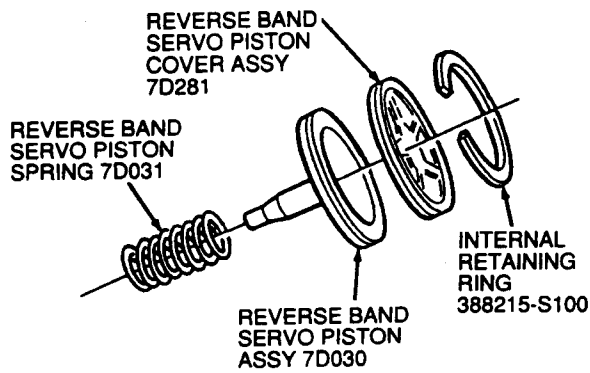

20. Use Servo Piston Remover / Replacer T92P-70023-A or equivalent to compress the low / reverse servo cover and remove retaining ring.
21. Remove servo cover, piston and piston return spring.

1-2 Accumulator

Removal

22. Apply downward pressure on 1-2 accumulator cover. Using snap-ring pliers, remove snap ring.
23. Remove cover and spring. Use reverse snap-ring pliers to remove accumulator piston and spring.

Carefully note the location of the 1-2 accumulator spring(s) and assemble in the same positions. Some models may use two springs. The piston may also vary with applications.

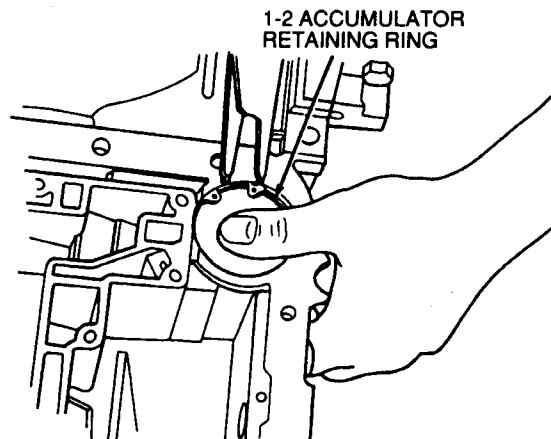

15. This illustration shows the position of the overdrive servo, the low reverse servo, 2-3 accumulator and the 1-2 accumulator.

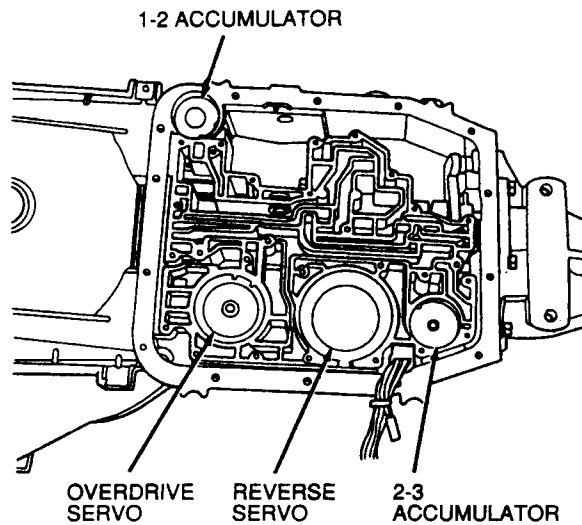

16. Remove the 2-3 accumulator retainer.
 17. Remove 2-3 accumulator piston and spring.

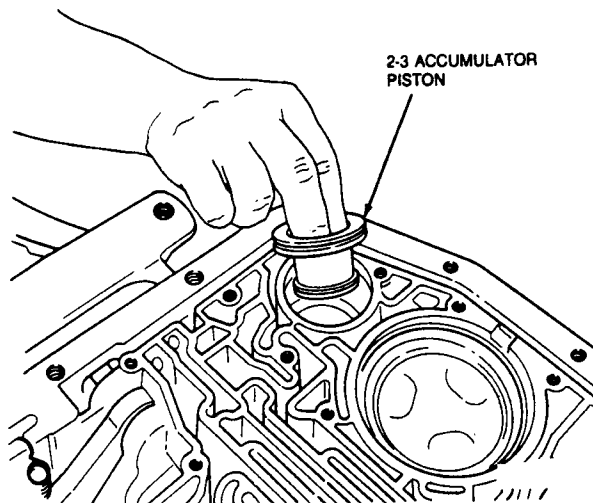

Subassemblies Overdrive Servo Removal

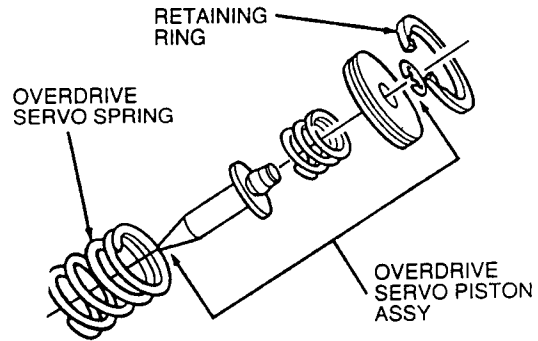

18. Use snap-ring pliers to remove snap ring. Use Servo Piston Remover / Replacer T92P-70023-A or equivalent, to compress the overdrive servo spring.

NOTE: If tool is not available, extreme care must be taken. Spring pressure will force piston assembly out of case. Case bore damage may result from trying to pry on snap ring.

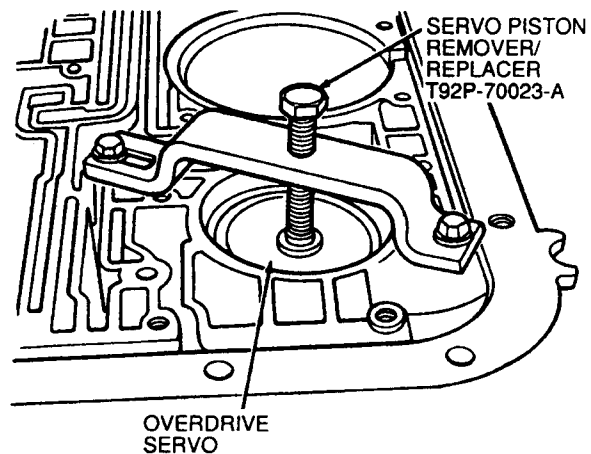

24. Remove filter from case.

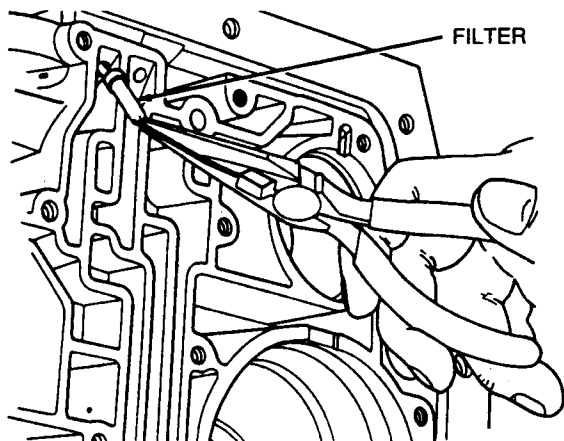

25. Remove extension housing seal. Using Seal Remover T74P-77248-A or equivalent. Ensure seal remover lips are firmly seated under the flange on the seal.

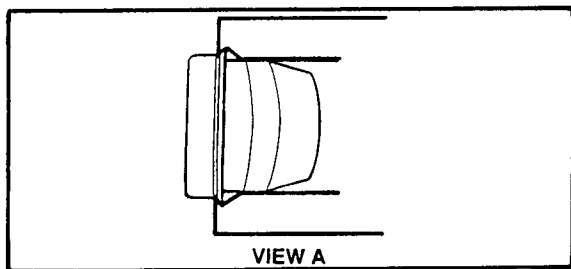
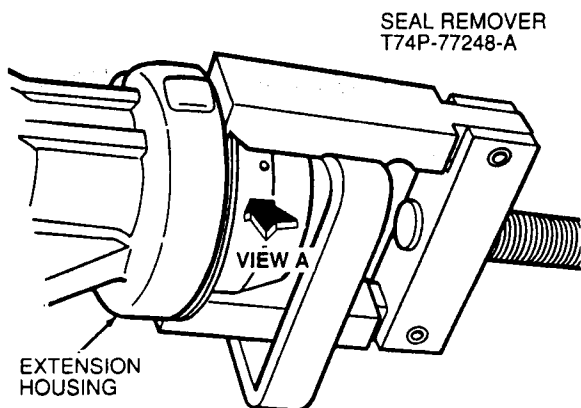

26. Inspect extension housing bushing. If required, remove the extension housing bushing using Extension Housing Bushing Remover T77L-7697-A or equivalent.

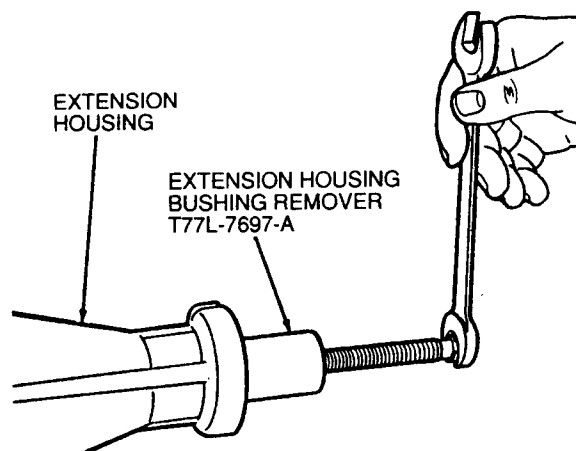

27. Remove six 13mm extension housing bolts. Remove and discard extension housing gasket.

NOTE: The extension housing bolts have been coated with a sealant. More break torque may be required to remove these bolts.

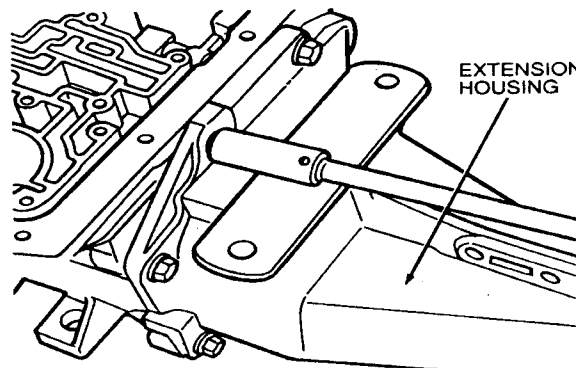

NOTE: The output shaft may have shipping seal still attached. Remove and discard. This seal is not required for assembly.

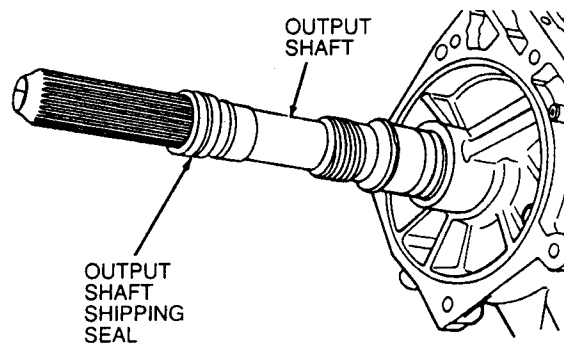

28. Slide park pawl shaft out of the case and remove park pawl and return spring.

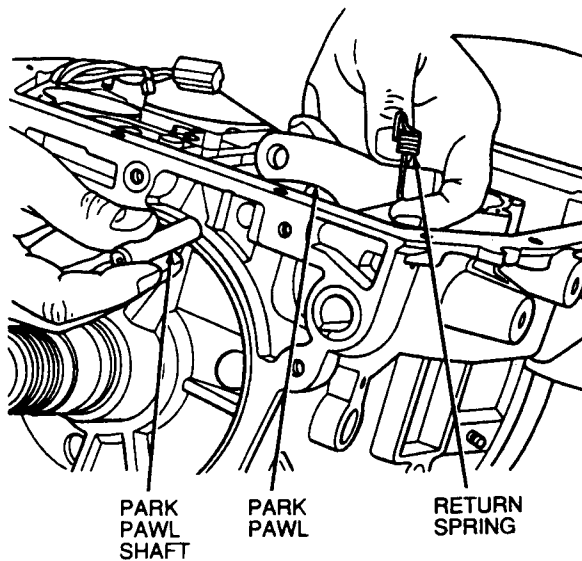

29. Remove output shaft snap ring and sleeve.

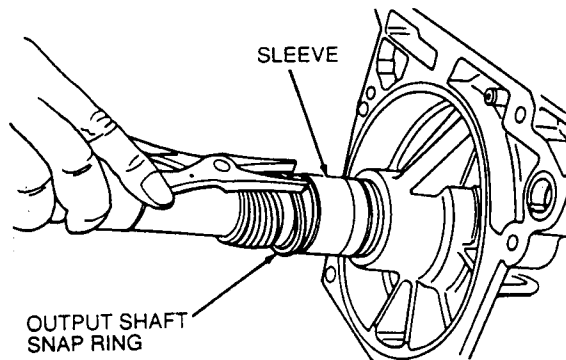

30. Place transmission in the vertical position with output shaft toward floor.
 31. Remove pump seal using Front Pump Seal Remover TOOL-1175-AC and Impact Slide Hammer T59L-100-B or equivalent.

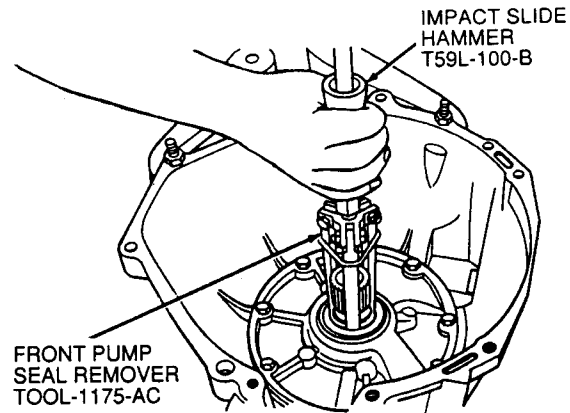

32. Remove transmission connector from case. Place a screwdriver on the flat portion of the connector and drive the connector out through the bottom of the case.

CAUTION: Extreme care must be taken during transmission connector removal.

CAUTION: Do not pull on the wires, or use a hammer on the connector body.

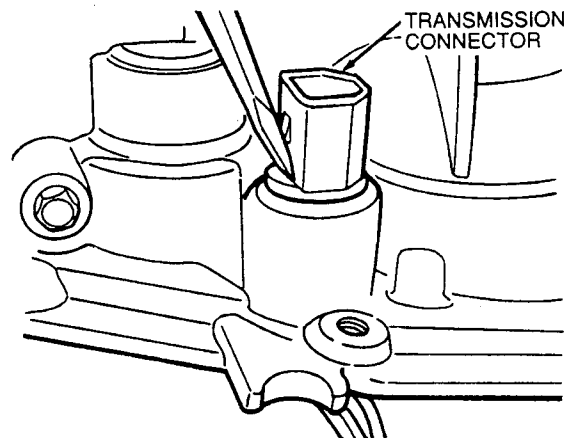

33. Remove seven 10mm pump body retaining bolts.

NOTE: All bolts have been coated with a sealant. More break torque might be required to remove bolts.

10MM BOLTS
7 REQ'D

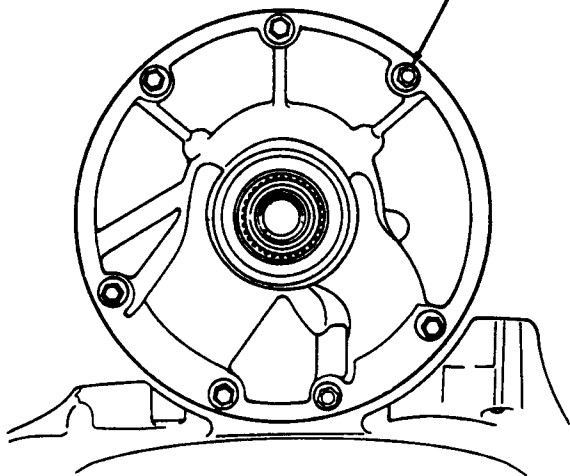

34. Remove pump assembly using two Impact Slide Hammers T59L-100-B and Front Pump Remover Adapters T80L-77103-A or equivalent.

35. Remove pump-to-case gasket.

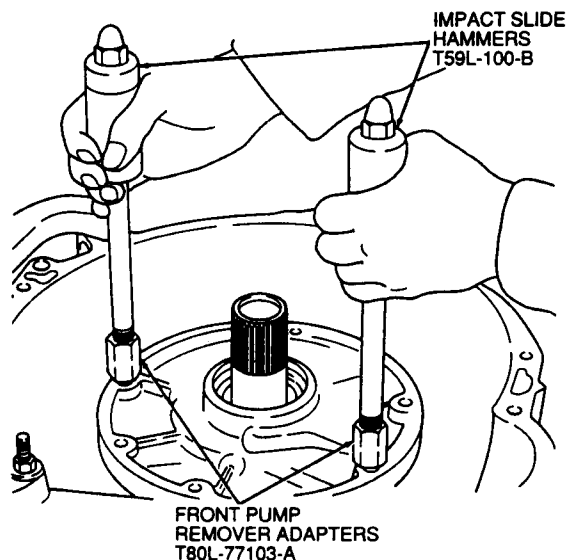

36. Grasp the turbine shaft firmly and pull the following components out of the case as an assembly:

- Intermediate clutch pack
- Intermediate one-way clutch
- Reverse clutch assembly
- Forward clutch assembly

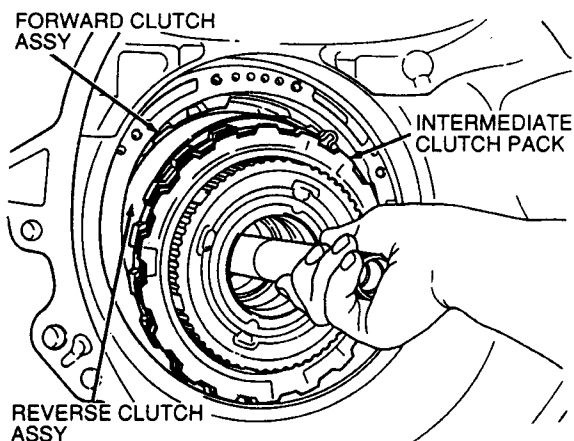

CAUTION: Remove the assembly carefully to prevent damage to the overdrive band friction material by the reverse clutch drive lugs.

37. Disengage overdrive band from anchor pin and remove.

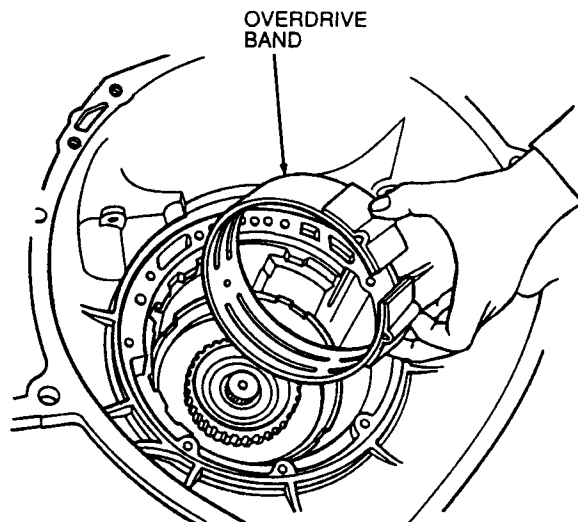

38. Remove forward clutch hub and the No. 3 needle bearing.

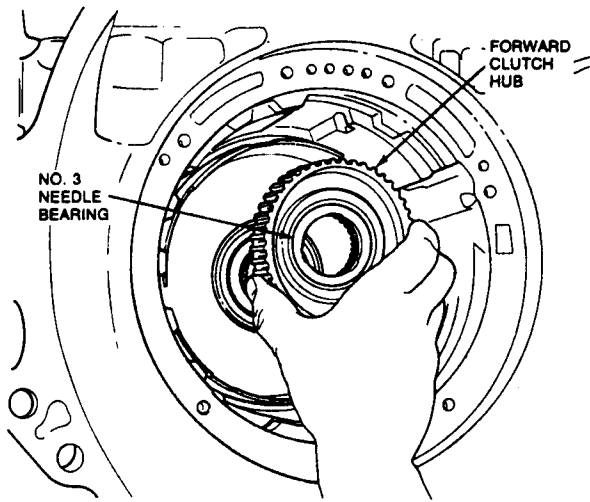

39. Remove intermediate stub shaft.

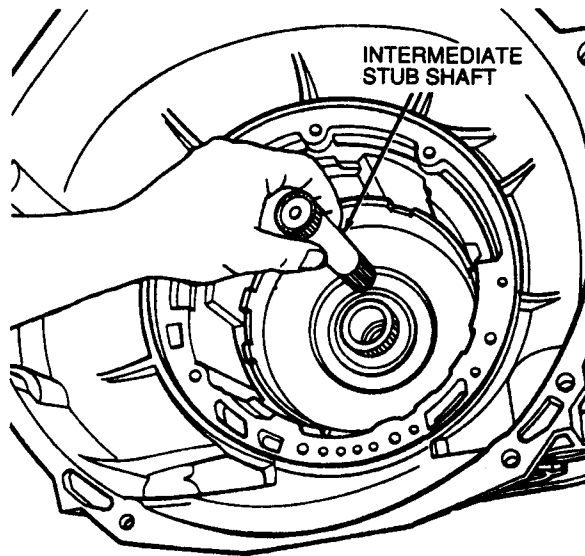

40. Rotate shell assembly to align indent with overdrive anchor pin.

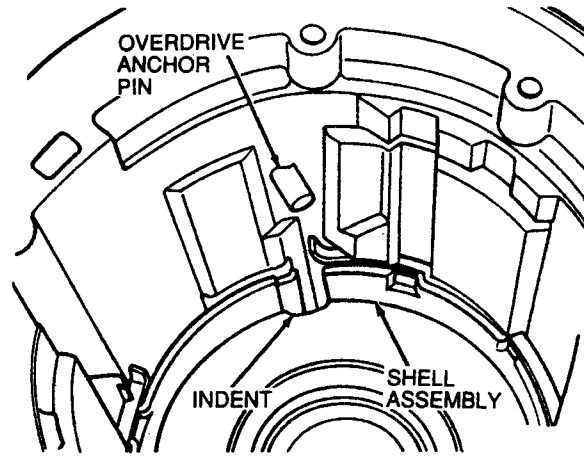

41. Remove forward sun gear, No. 5 needle bearing, reverse sun gear and drive shell assembly and the No. 4 needle bearing as an assembly.

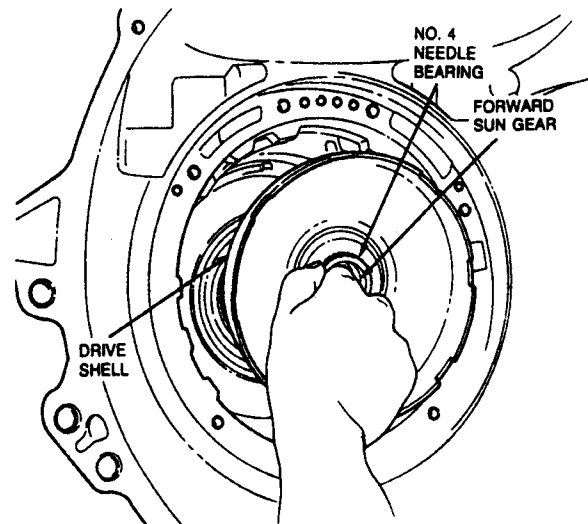

42. Remove center support retaining ring. Note position of snap ring tabs for assembly.

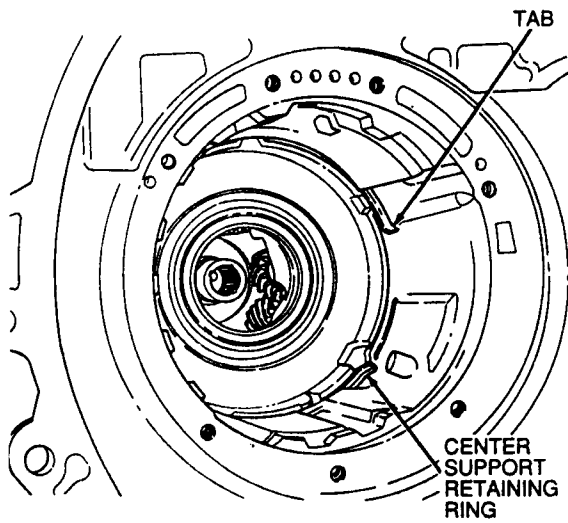

43. Using needle-nose pliers, remove anti-clunk spring out from between the center support and the case. Note location for assembly.

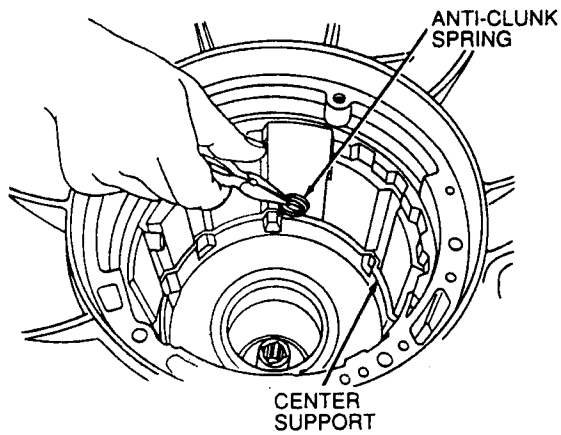

44. Remove center support and planetary carrier as an assembly.

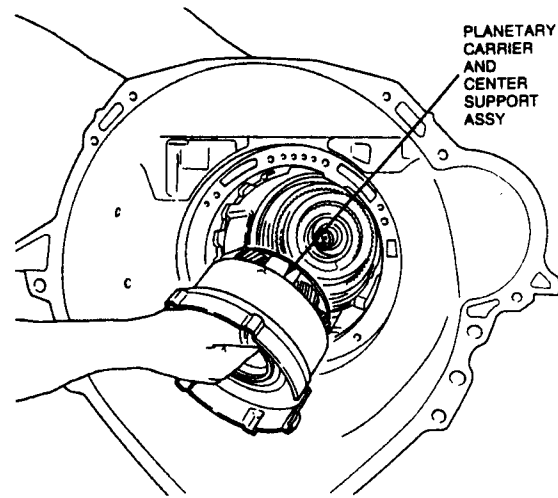

45. Remove low/reverse band.

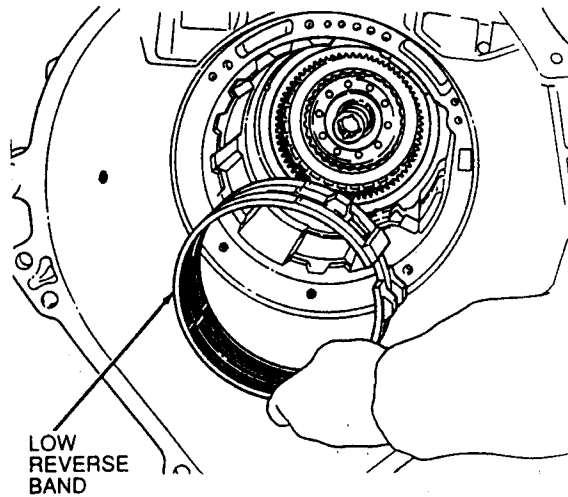

46. Remove output shaft, ring gear and direct clutch as a unit, from the front of the case.

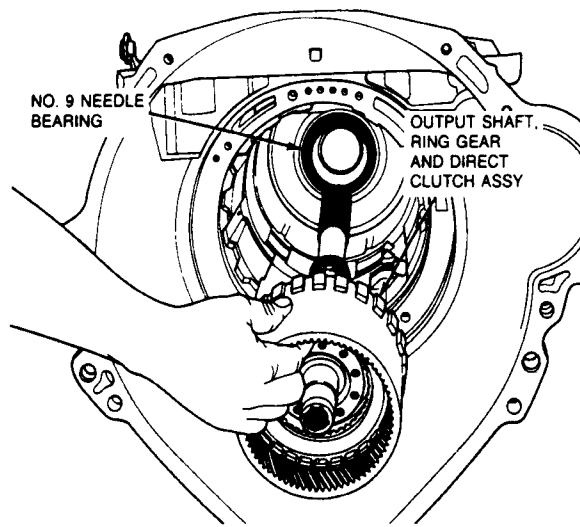

47. Remove output shaft No. 9 needle bearing from rear of the case.

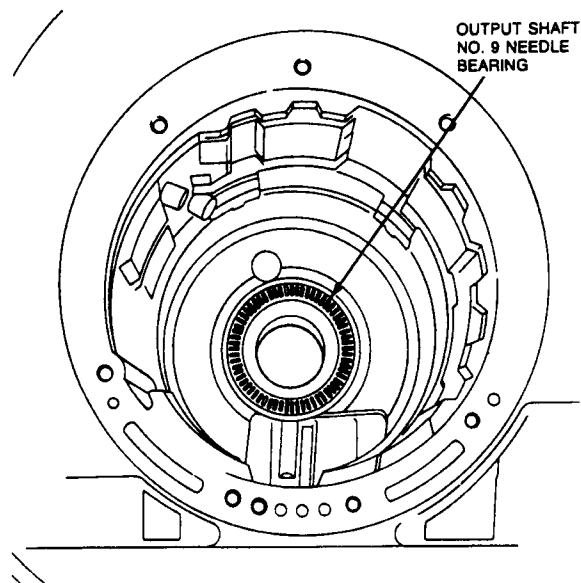

48. Inspect output shaft bushing. If removal is required, use Bearing Cup Puller T77F-1102-A and Impact Slide Hammer T59L-100-B or equivalent.

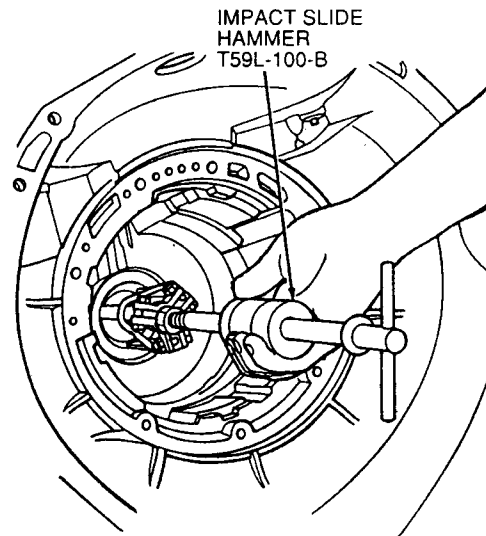

1. Remove ring retaining the output shaft hub to ring gear.

NOTE: Governor sleeve and block pin need only be removed when major component failure requires transmission cleaning and overhaul.

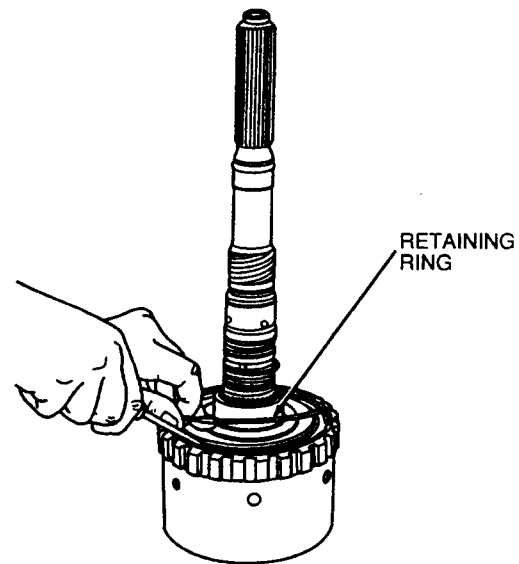
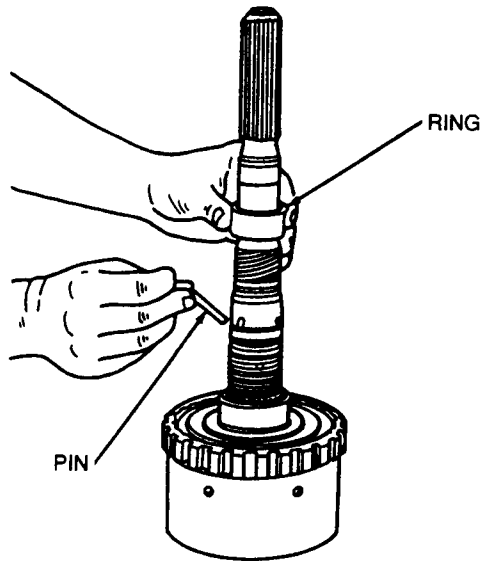

2. Separate output shaft from ring gear.

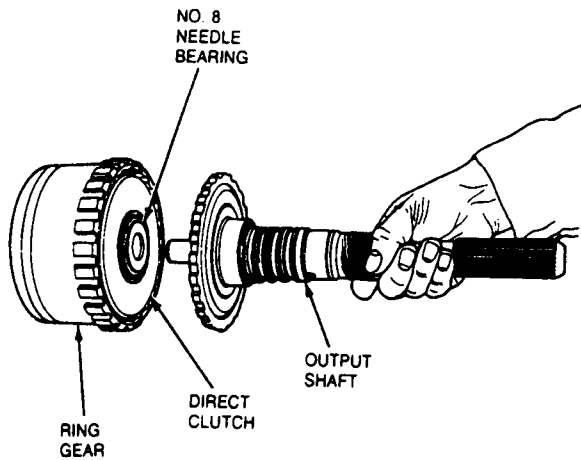

3. Remove snap ring retaining output shaft hub. Slide hub off rear of shaft.

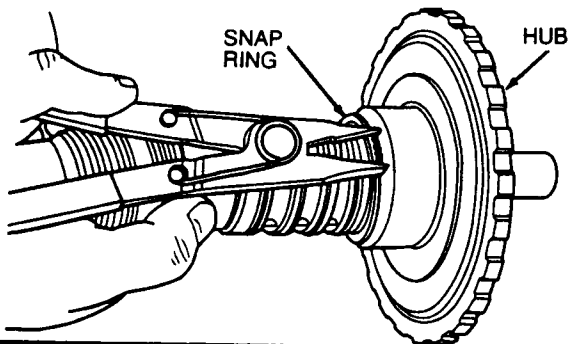

4. Remove three output shaft seal rings and output shaft O-ring.

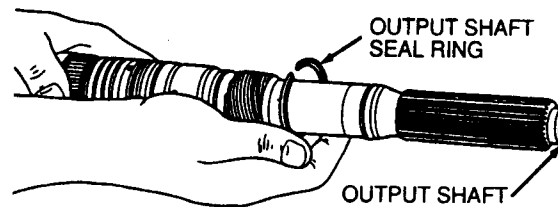

5. Remove two direct clutch seal rings from the output shaft. Note the direction of the scarf-cut seals.

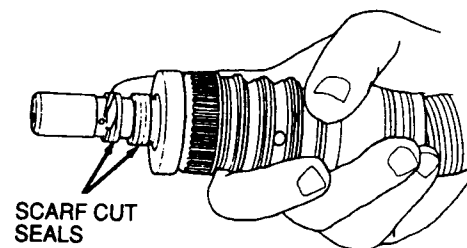

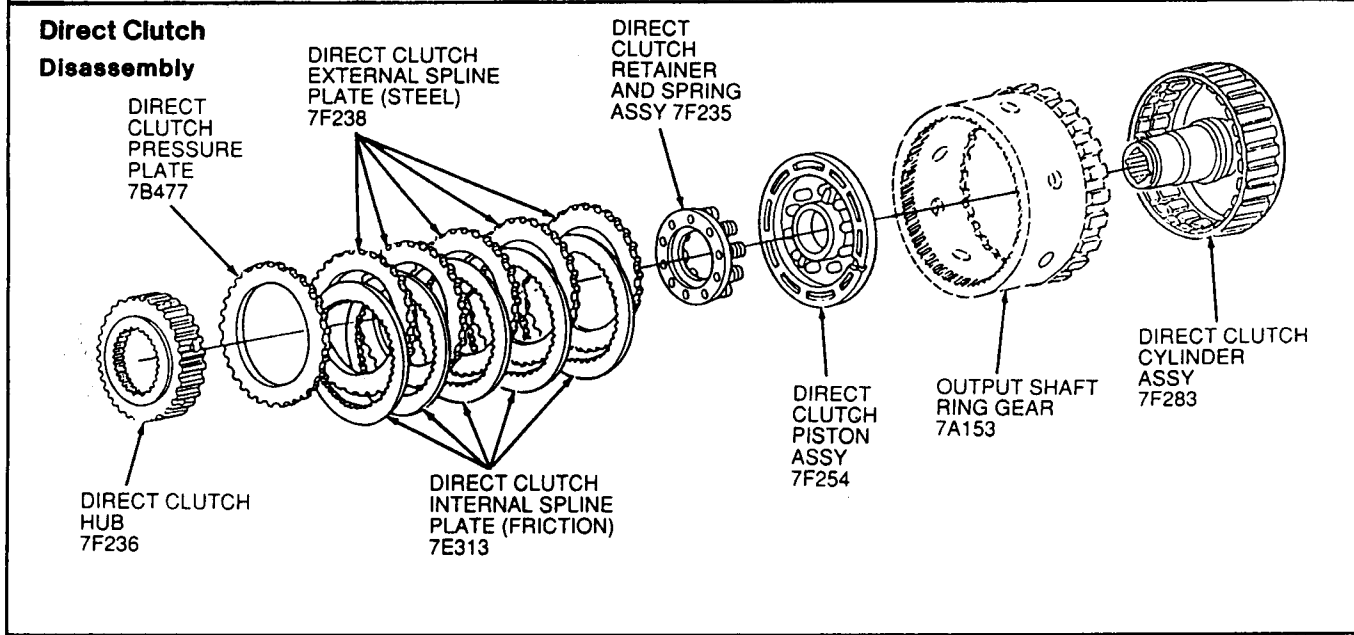
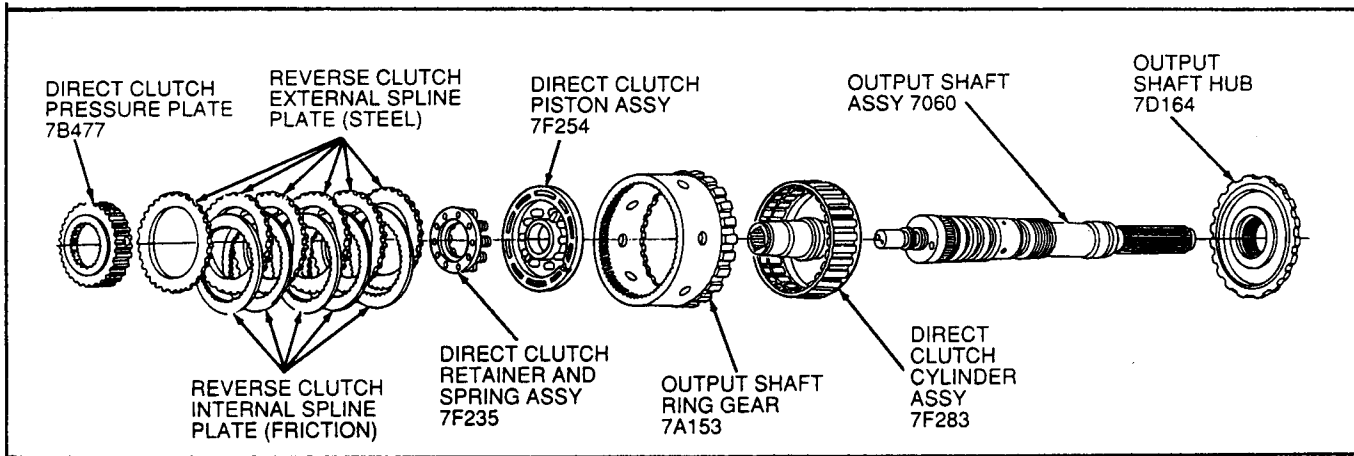

1. After removing direct clutch hub, remove No. 7 bearing and bearing support.

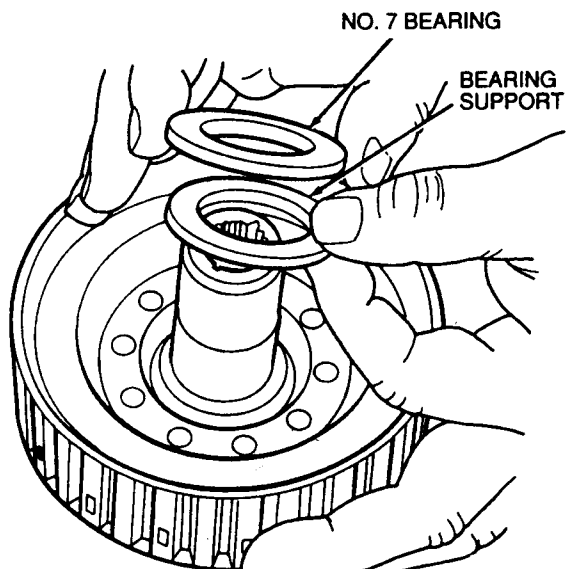

2. With snap ring removed, remove and inspect clutch pack. Note the relation of clutch plates for assembly.

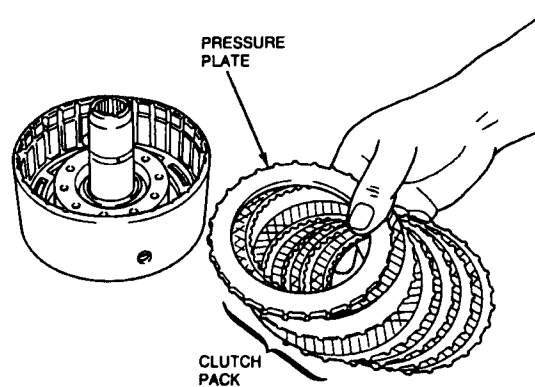

D3285-B

3. Using Direct Clutch Spring Compressor T81P-70235-A or equivalent compress the piston return spring. Remove piston retaining ring using expanding-type snap-ring pliers.

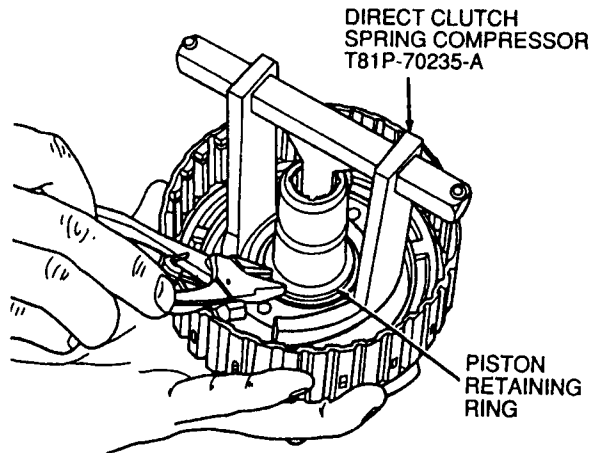

4. Remove spring retainer assembly and piston from cylinder.

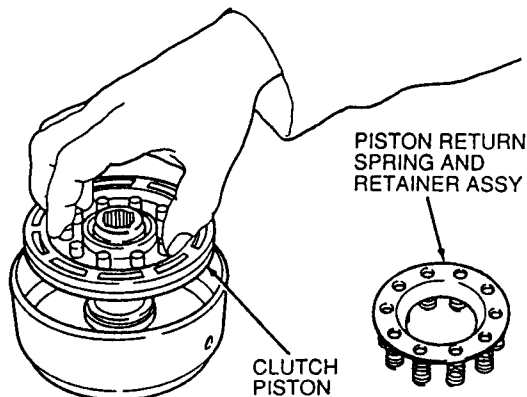

NOTE: Use air pressure if necessary to remove clutch piston.

Remove inner seal from cylinder hub and outer seal from piston. Verify presence of check ball and that it moves freely.

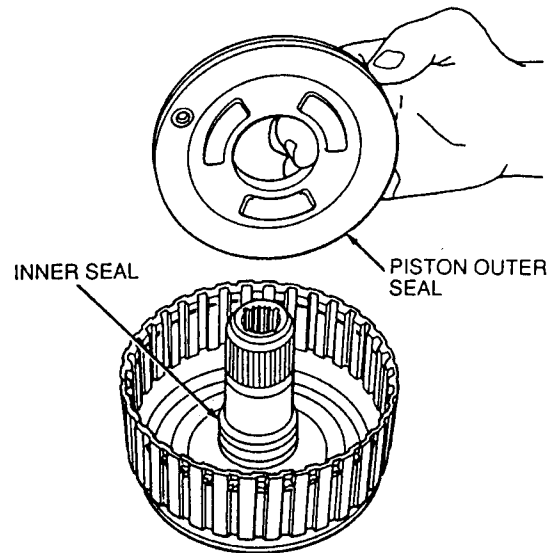

Assembly

1. Install inner piston seal on clutch cylinder hub as follows:
 - a. Position Direct Clutch Lip Seal Protector T80L-77234-A or equivalent over clutch cylinder hub.
NOTE: Lubricate seal and seal protector with petroleum jelly.
 - b. Position seal over installer tool with the sealing lip facing down.

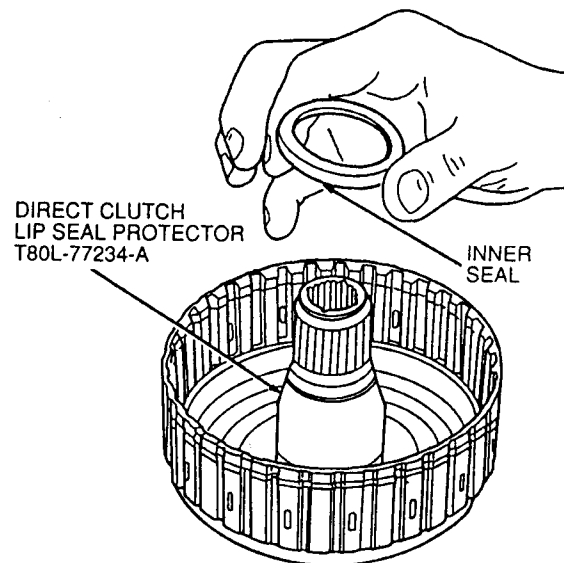

2. Install clutch piston outer seal. Note direction of sealing lip before installation. The lip should point toward bottom of cylinder.

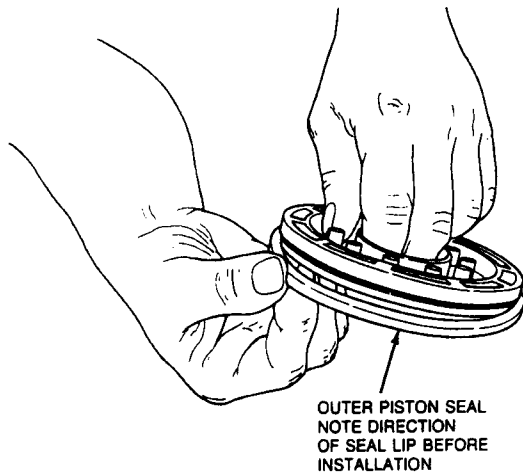

3. Install clutch piston as follows:

NOTE: Coat inner and outer piston seals, clutch cylinder sealing area and piston inner sealing area with petroleum jelly.

- a. Install piston in Lip Seal Protector T80L-77254-A or equivalent.

Position tool in the clutch drum and push the piston to the bottom of the drum using even thumb pressure.

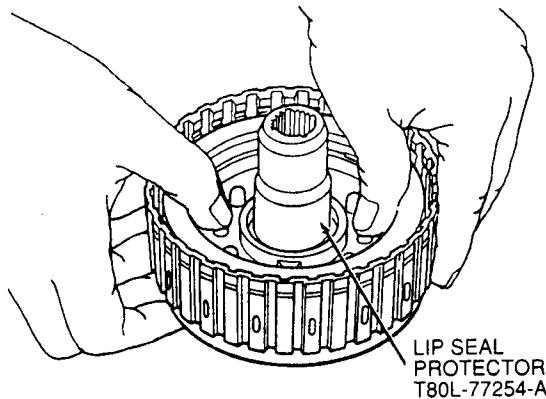

4. Install piston spring, retainer assembly and retaining ring using Direct Clutch Spring Compressor T81P-70235-A or equivalent.

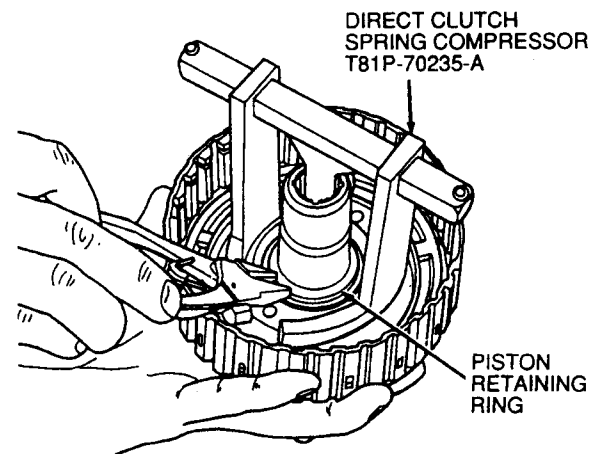

5. Install clutch pack.

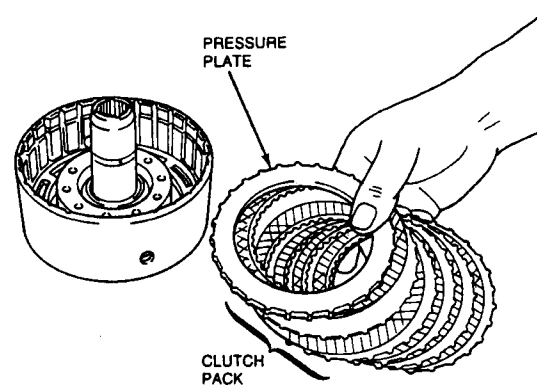

6. With retaining ring installed, check clearance between ring and pressure plate using a feeler gauge.

Pressure plate should be held downward as the clearance is checked.

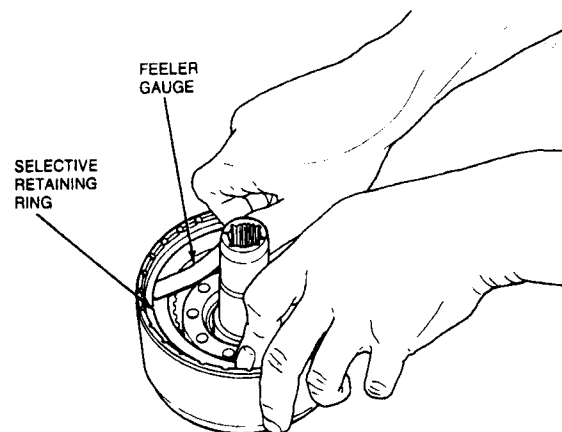

7. The clearance should be:

4.6L (CID) SEFI,

- Six Plate 1.52-2.33mm (0.060-0.091 inch).

— If the clearance is not within limits, selective snap rings are available in the following thicknesses:

- 1.27-1.37mm (0.050-0.054 inch)
- 1.62-1.72mm (0.064-0.068 inch)
- 1.98-2.08mm (0.078-0.082 inch)
- 2.33-2.43mm (0.092-0.096 inch)

— Install the correct size snap ring and check the clearance.

8. Install No.7 needle bearing support and No. 7 needle bearing (black side up toward direct clutch hub).

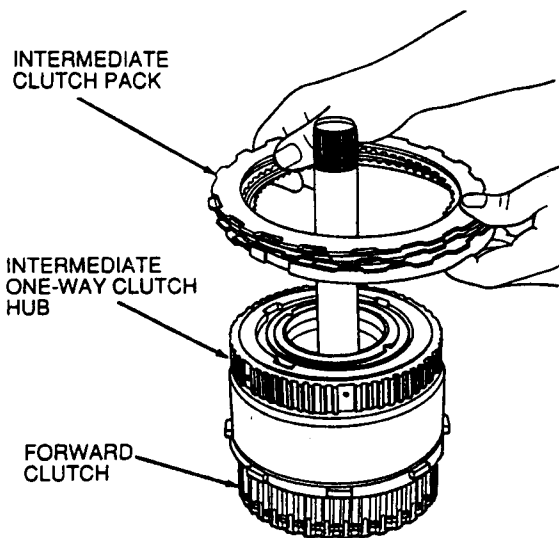

9. Install direct clutch hub.

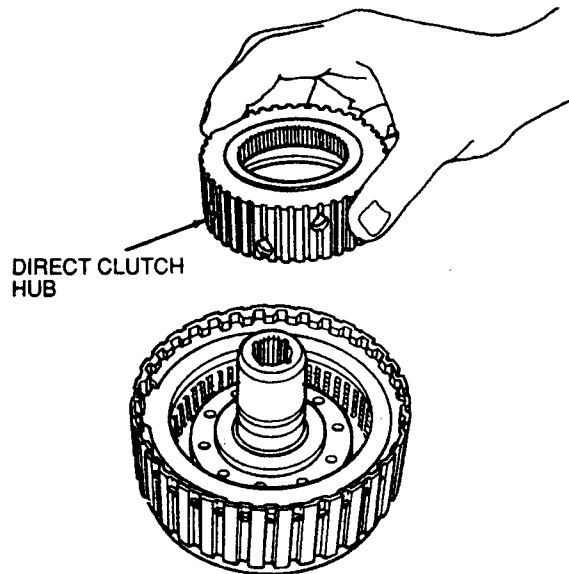

10. To assemble output shaft, direct clutch assembly and ring gear, reverse Removal procedure.

11. Install following components as an assembly:

- Intermediate clutch pack
- Intermediate one-way clutch
- Reverse clutch
- Forward clutch

12. Remove intermediate clutch pack from intermediate one-way clutch hub.

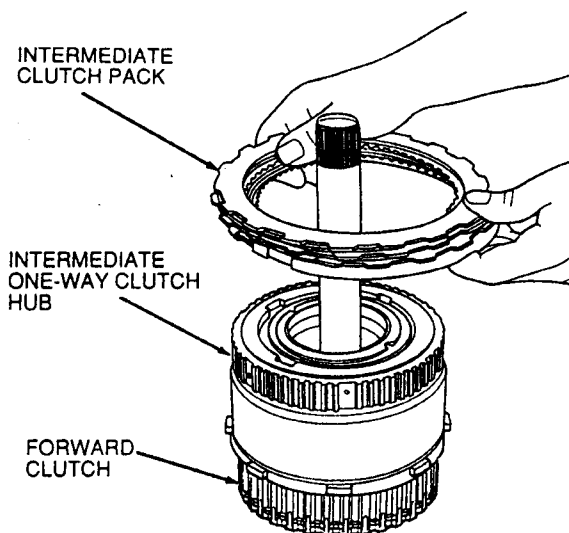

13. Remove reverse clutch assembly from forward clutch assembly.

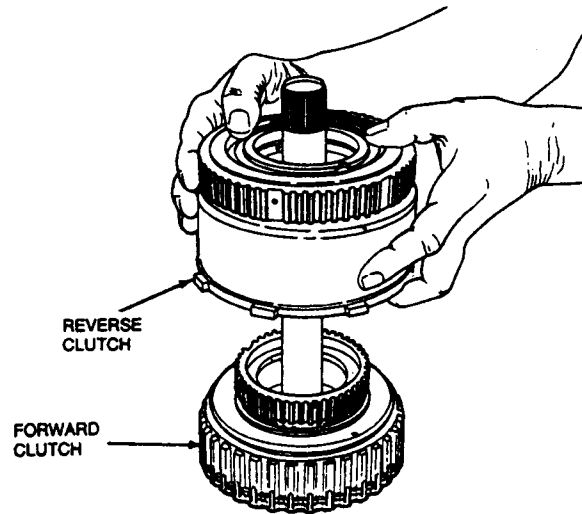

Intermediate One-Way Clutch

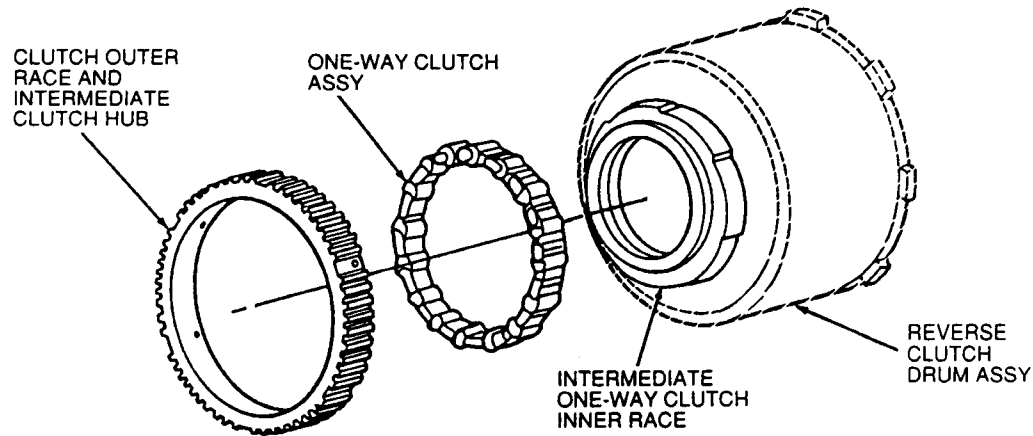

Disassembly and Assembly

1. Remove clutch retaining ring.

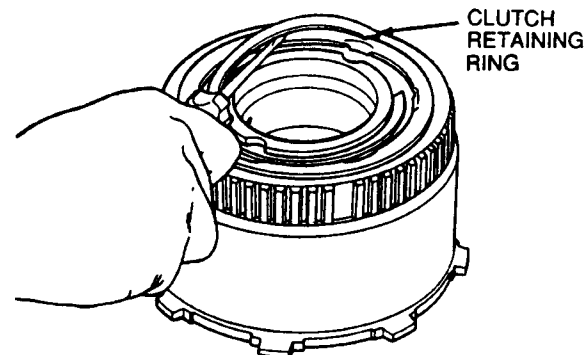

2. Remove clutch retaining plate.

CLUTCH
RETAINING PLATE

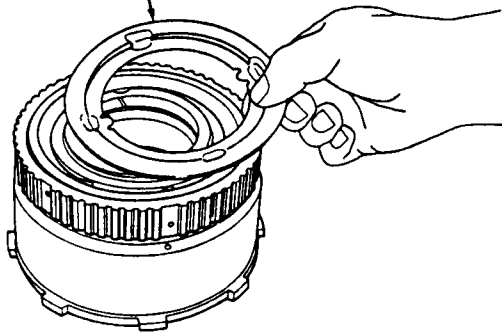

3. Remove clutch outer race by lifting on the race while turning counterclockwise.
Carefully lift one-way clutch from inner race.

OUTER
RACE

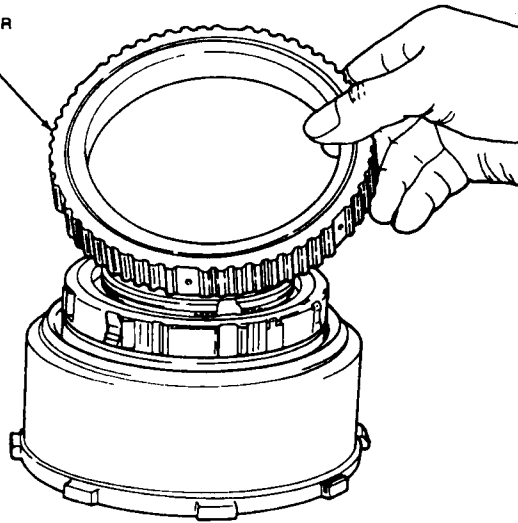

4. To assemble intermediate one-way clutch reverse Removal procedure.

NOTE: For ease in assembly, the chamfer on the outer clutch race splines should face upward.

CHAMFER

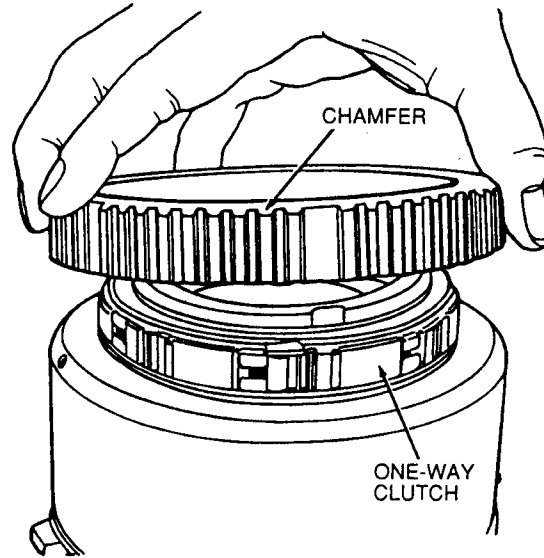

ONE-WAY
CLUTCH

Reverse Clutch Disassembly

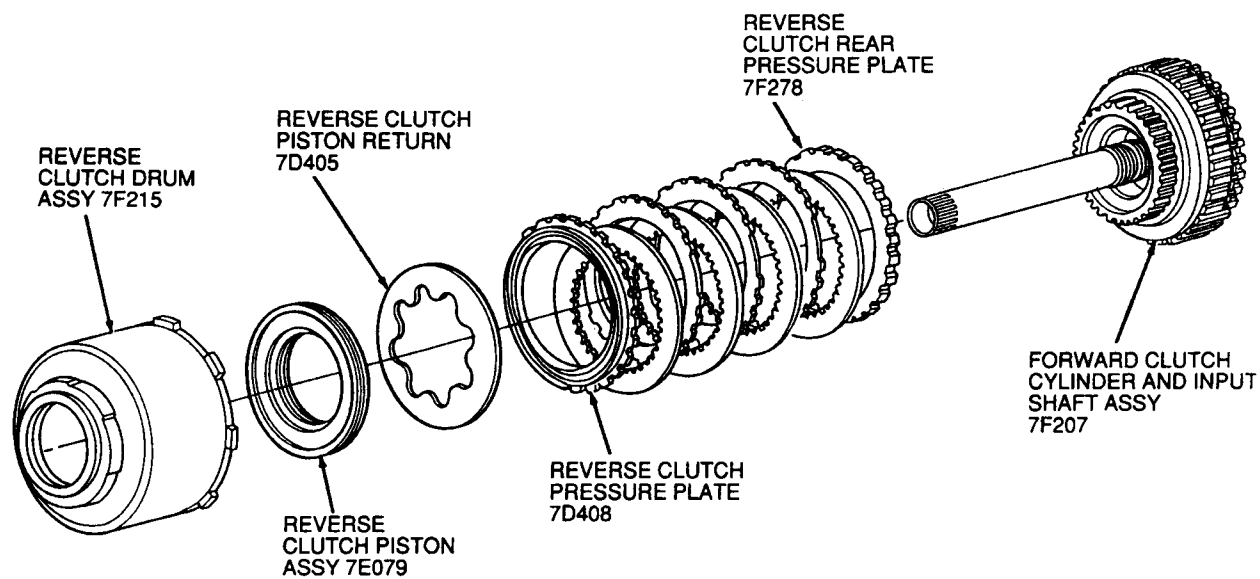

1. Remove No. 2 needle bearing.

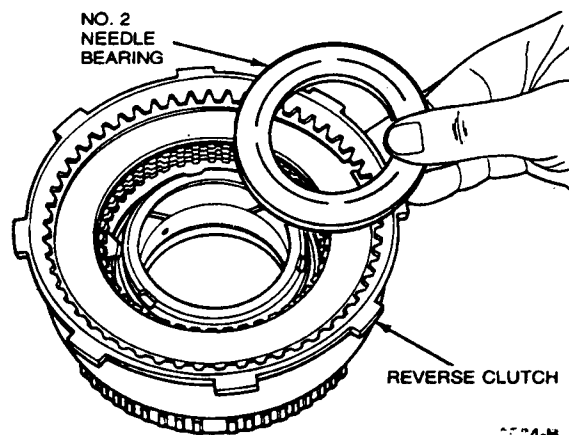

2. Remove selective clutch pack retaining ring.

SELECTIVE CLUTCH PACK RETAINING RING

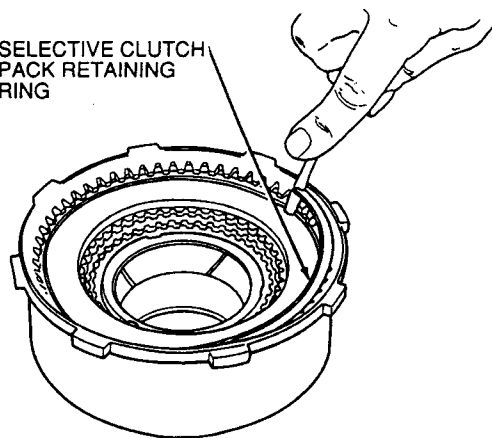

3. Remove clutch pack.

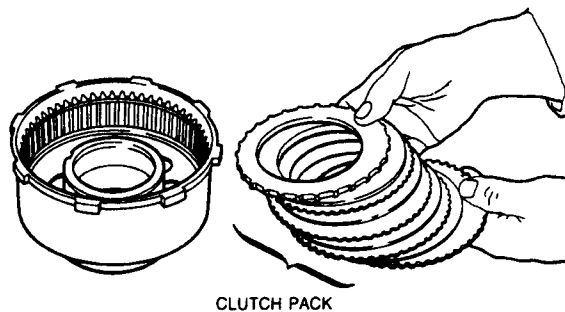

4. Install Direct Clutch Spring Compressor Tool T81P-70235-A or equivalent onto reverse clutch. Tighten enough to compress return spring. Remove retaining ring.

DIRECT CLUTCH
SPRING COMPRESSOR
TOOL T81P-70235-A

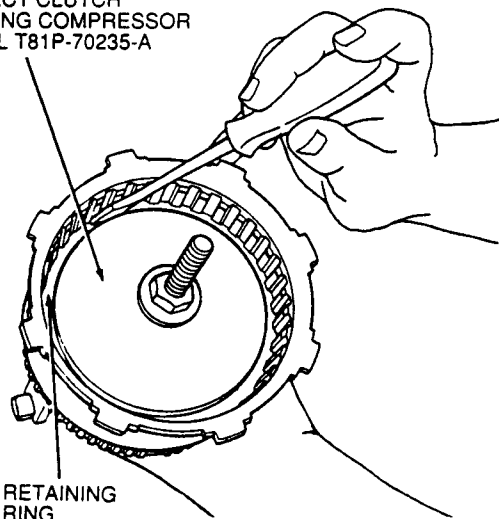

5. Remove piston, Belleville return spring and thrust ring.

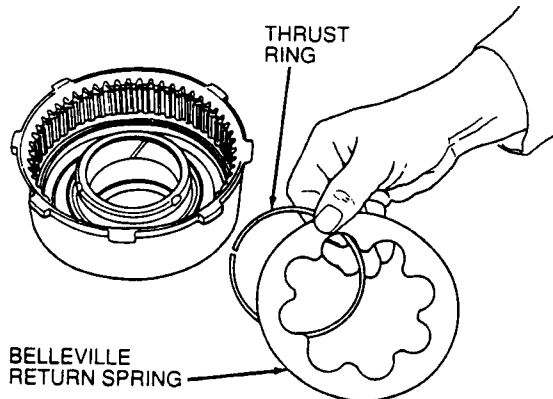

6. Remove clutch piston and inner and outer piston seals.

NOTE: To aid in piston removal, it may be necessary to apply air pressure to the drum. Block the opposite hole with a finger.

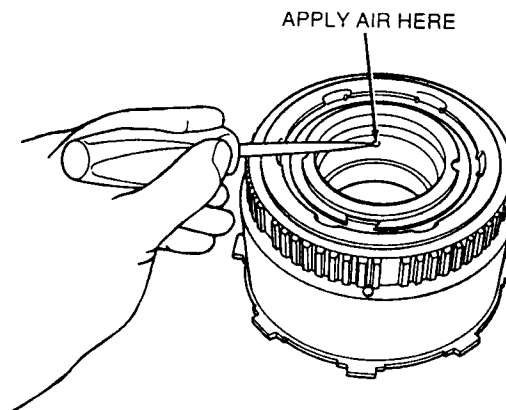

Assembly

1. Install new seals on clutch piston. Direction of installation is not important because seals are square cut.

NOTE: The piston check ball must be present and moving freely.

NOTE: THE SEALS ARE SQUARE AND THEREFORE CAN BE INSTALLED IN EITHER DIRECTION.

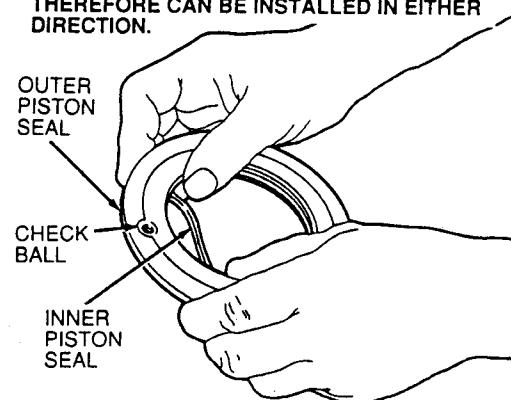

2. Install clutch piston as follows:

NOTE: Coat piston seals, clutch drum, sealing area and seal protector with petroleum jelly.

- a. Install Reverse Clutch Seal Protector (Inner) T80L-77403-B or equivalent on the clutch hub and Reverse Clutch Seal Protector (Outer) T80L-77403-A or equivalent over the piston.

- b. Position piston and push it to the bottom of the drum using even thumb pressure.

REVERSE CLUTCH
SEAL PROTECTOR
(INNER)
T80L-77403-B

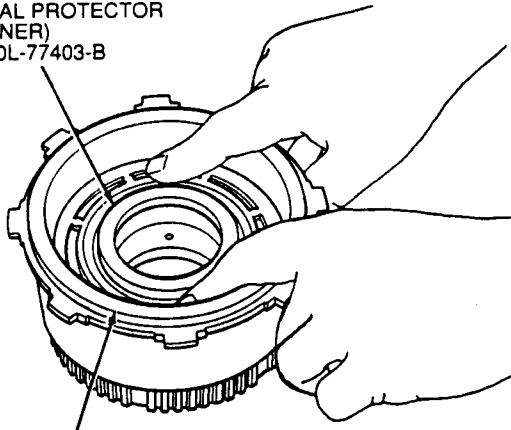

REVERSE CLUTCH
SEAL PROTECTOR
(OUTER) T80L-77403-A

3. Install piston thrust ring and piston Belleville return spring. The dished side of spring must face toward the piston.

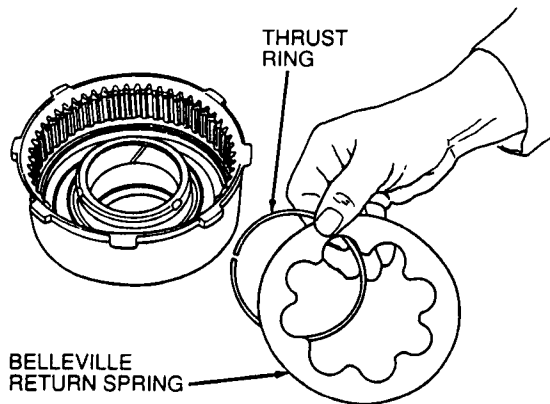

4. Install wave snap ring (with points down) using Direct Clutch Spring Compressor Tool T81P-70235-A or equivalent.

DIRECT CLUTCH
SPRING COMPRESSOR
TOOL T81P-70235-A

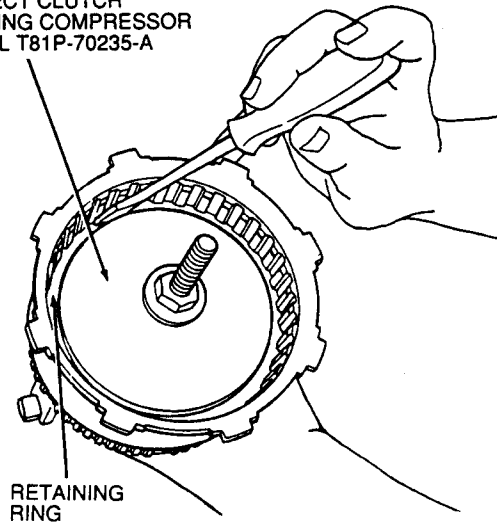

5. Install front pressure plate, clutch pack and rear pressure plate. Position the stepped side of front pressure plate down with flat side toward clutch pack and rear pressure plate flat side toward clutch pack.

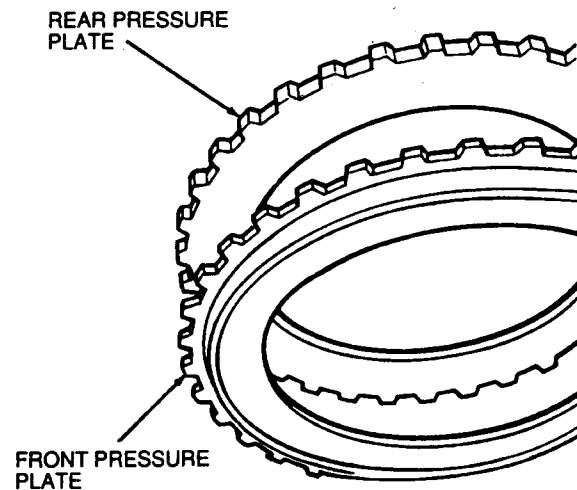

6. Install clutch pack retaining ring and check the clearance between the ring and the pressure plate using a feeler gauge. Pressure plate should be held downward as clearance is checked.

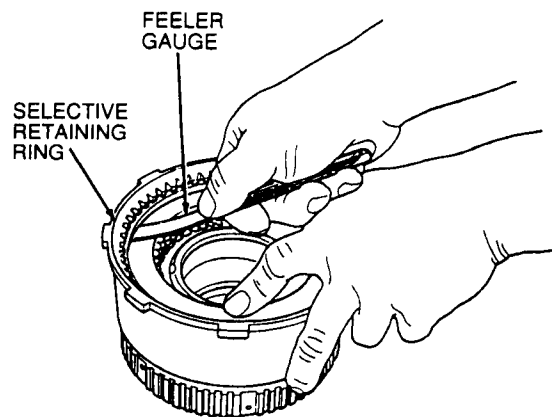

The clearance should be:

4 plate assembly

- 1.01-1.524mm (0.040-0.059 inch)

If clearance is not within specification, selective snap rings are available in the following thicknesses:

- 1.27-1.37mm (0.060-0.064 inch)
- 1.87-1.98mm (0.074-0.078 inch)
- 2.23-2.33mm (0.088-0.092 inch)
- 2.59-2.69mm (0.102-0.106 inch)

Install correct size snap ring and check clearance.

7. Check clutch for proper operation using Air Nozzle TOOL-7000-DE or equivalent. The clutch should be heard and felt to work smoothly and without leakage.

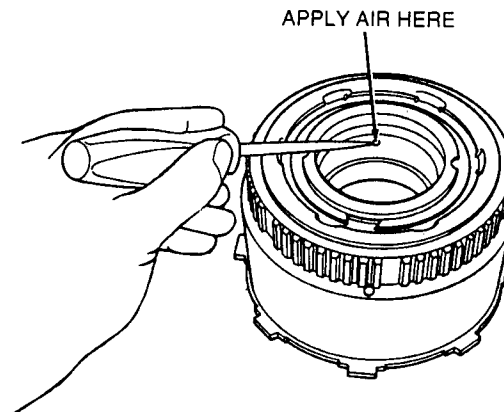

Forward Clutch Disassembly

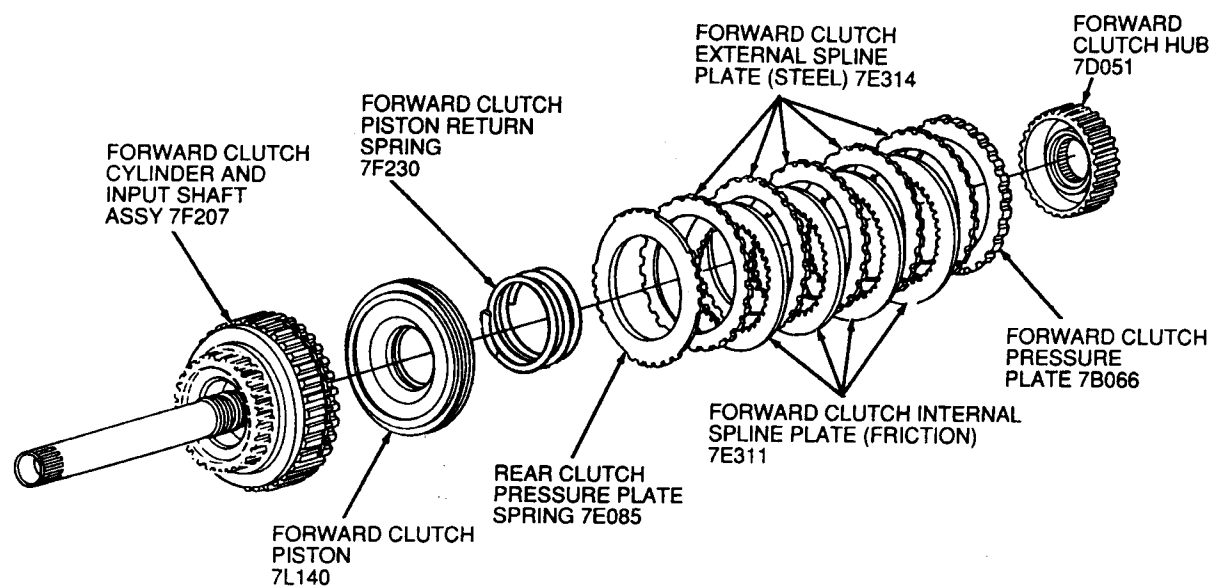

1. Remove clutch hub and No. 3 needle bearing, if not already removed.

NOTE: Clutch hub may remain in shell during disassembly.

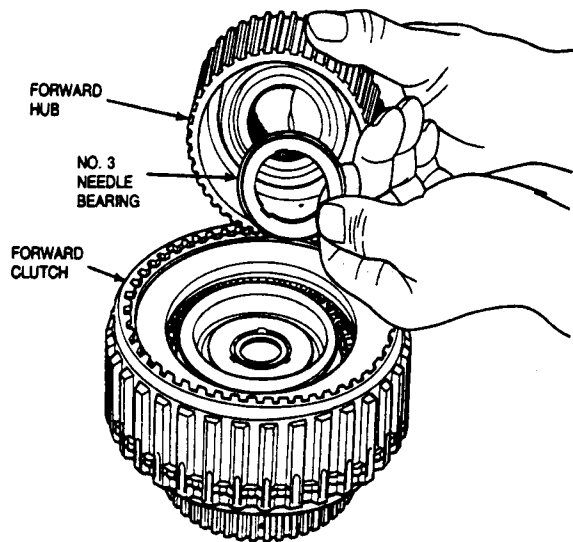

2. Remove clutch pack selective retaining ring.

NOTE: To aid handling, clutch may be set in the extension housing or a 51mm (2 inch) diameter hole may be cut in the work bench.

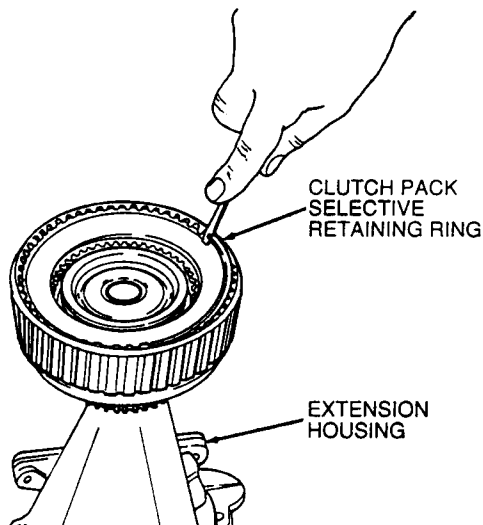

3. Remove clutch pack, pressure plate, clutch plates and wave spring.

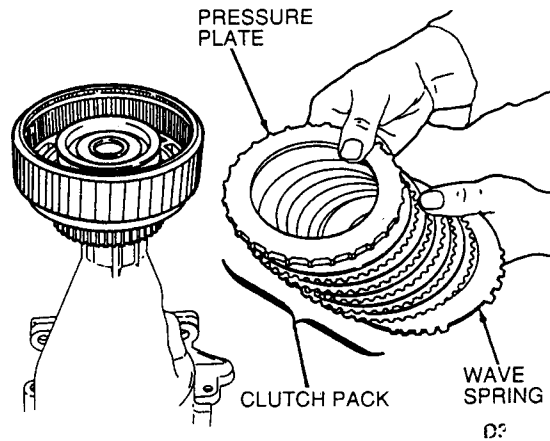

4. Compress piston return spring using Direct Clutch Spring Compressor T81P-70235-A or equivalent.

Place into a shop arbor press and apply only enough pressure to release spring tension on the snap ring.

Remove retaining ring and slowly release the press to remove spring compressor.

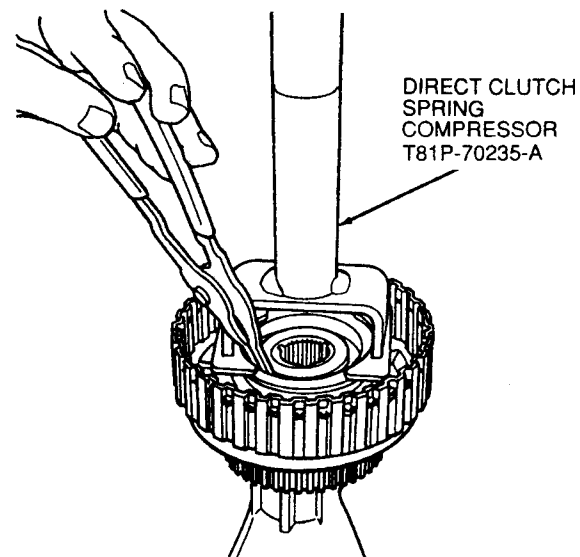

5. Remove spring retainer, return spring and piston.
6. Remove piston and inner and outer piston seals.

NOTE: Air pressure may be required to remove piston.

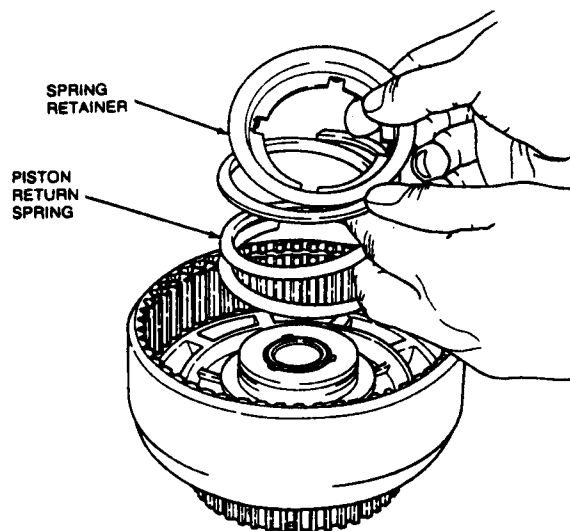

7. Remove scarf-cut seals from forward clutch cylinder shaft.

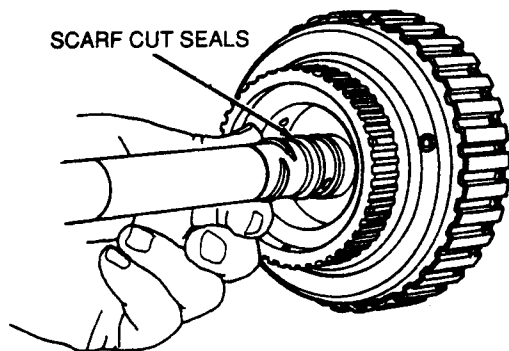

NOTE: Ensure check balls in clutch cylinder are free and clean. Check for proper seating.

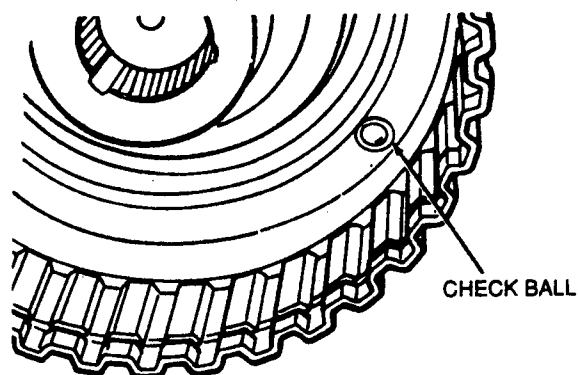

Assembly

1. Install new seals on clutch piston. Note direction of the sealing lip before installation.

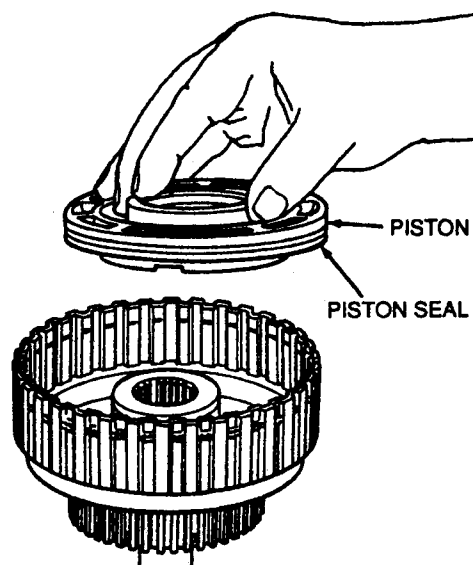

2. Install clutch piston as follows:

NOTE: Coat piston seals and clutch drum sealing area with petroleum jelly.

- a. Install Forward Clutch Lip Seal Protector (Inner) T80L-77 140-A or equivalent over clutch cylinder hub.

- b. Install piston in Forward Clutch Lip Seal Protector (Outer), T68P-7D158-A or equivalent.

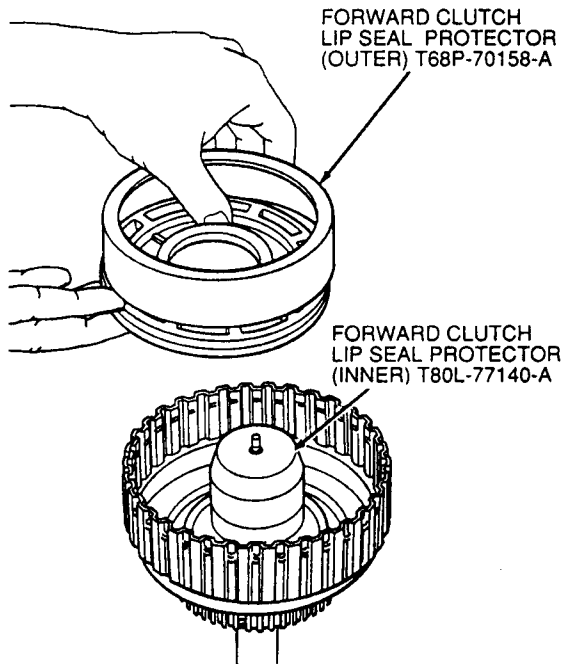

3. Position seal protector and piston in clutch drum. Push piston to the bottom of the drum using even thumb pressure. Remove seal protectors.

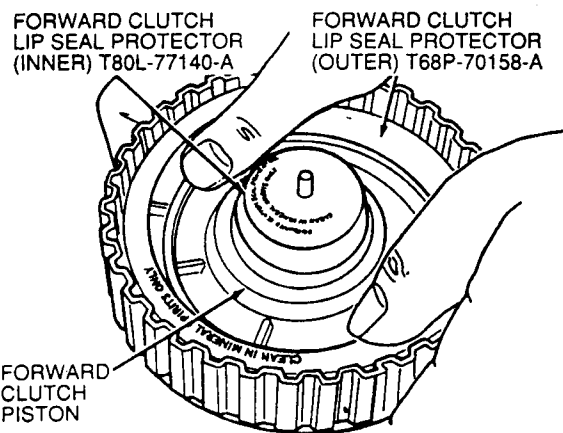

4. Install piston return spring and spring retainer.
5. Compress piston return spring using Direct Clutch Spring Compressor T81P-70235-A or equivalent. Compress piston only enough to allow clearance to install retaining ring.

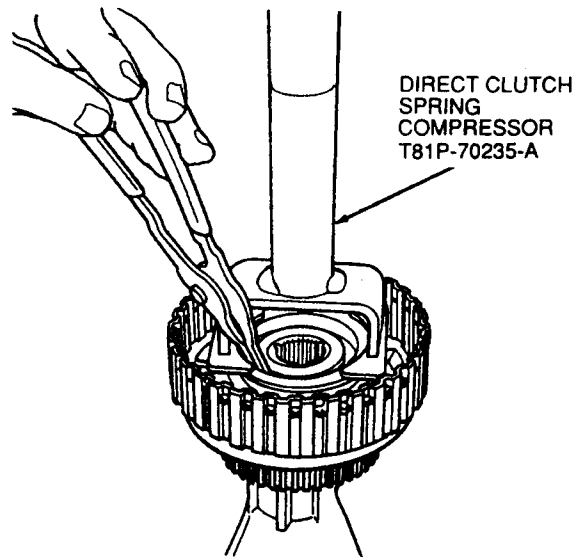

6. Install clutch pack in the following order:
- Wave spring
 - Clutch pack
 - Pressure plate

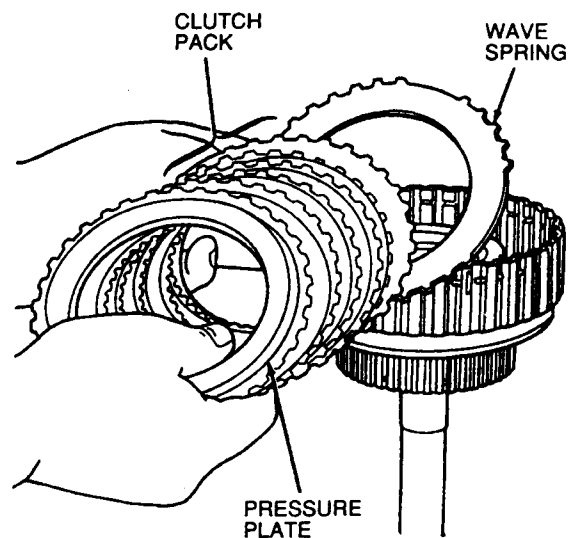

7. Install clutch pack retaining ring and check the clearance between the ring and pressure plate using a feeler gauge.

Pressure plate should be held downward as the clearance is checked.

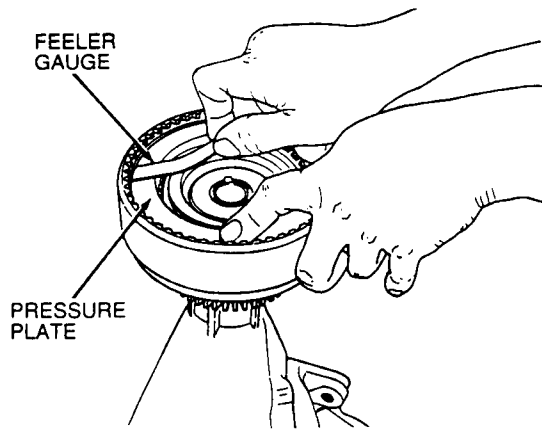

8. Install two scarf-cut seals on the forward clutch shaft.

NOTE: Scarf-cut seals must be installed with mating surfaces as shown.

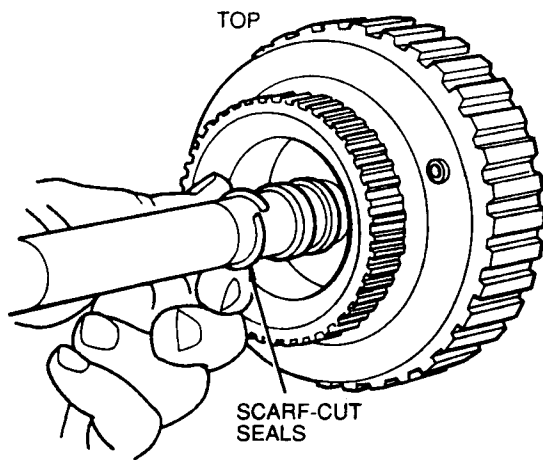

The clearance should be:

- 1.27-2.26mm (0.50-0.089 inch)

If the clearance is not within specification, selective snap rings are available in the following thicknesses:

- 1.27-1.37mm (0.060-0.064 inch)
- 1.87-1.98mm (0.074-0.078 inch)
- 2.23-2.69mm (0.086-0.092 inch)
- 2.59-2.69mm (0.102-0.106 inch)

Install the correct size snap ring and recheck the clearance.

9. Install No. 3 needle bearing. Install hub into forward clutch, ensure hub is against No. 3 bearing.

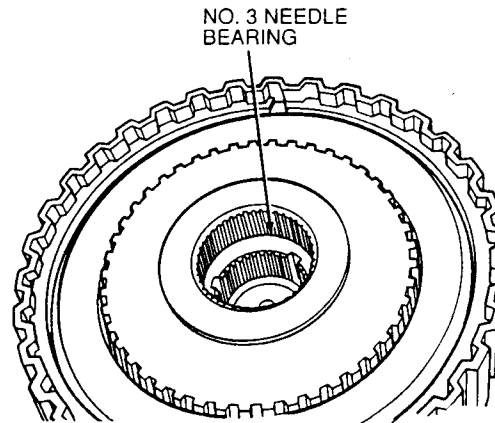

Center Support and Planetary One-Way Clutch Disassembly

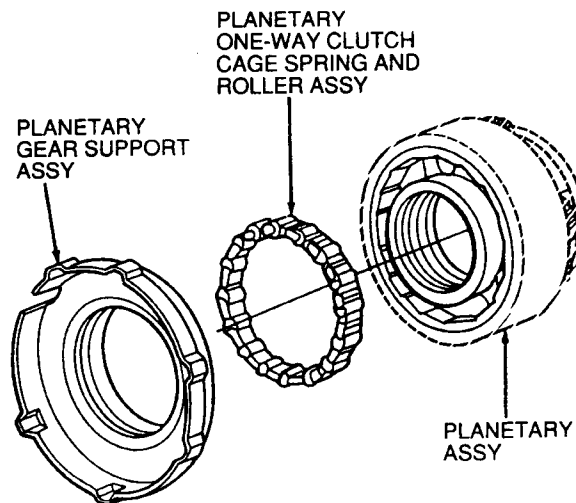

1. Remove center support from planetary carrier. Rotate the center support counterclockwise and lift.

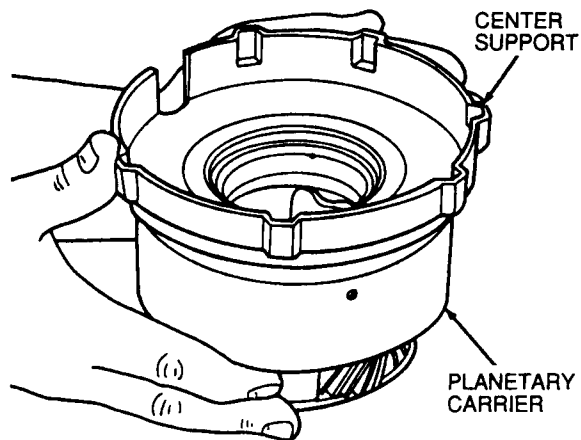

2. Carefully remove planetary one-way clutch from planetary assembly.

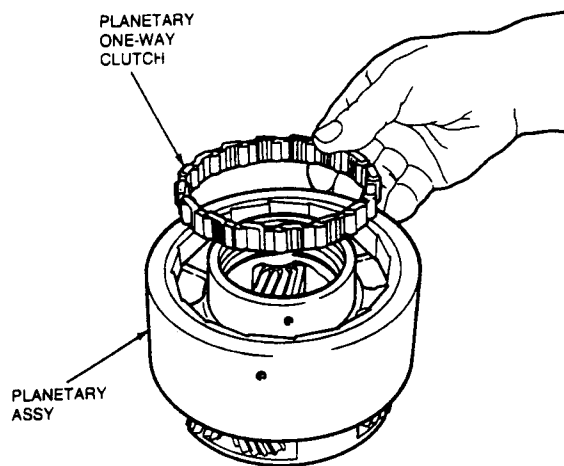

Assembly

1. Inspect clutch outer race, inner race, band surface, pinion gears, bearings and thrust washer for roughness.
Inspect center support bushing for roughness.
Inspect one-way clutch, rollers and springs for damaged rollers and broken springs.

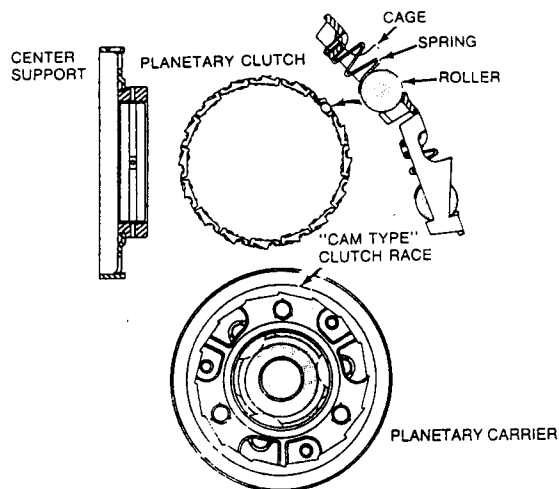

2. Install one-way clutch in planetary carrier.
3. Install center support into one-way clutch by rotating the center support counterclockwise.
Lubricate clutch races and clutch assembly with petroleum jelly to aid in assembly.

Sun Gear and Drive Shell Disassembly

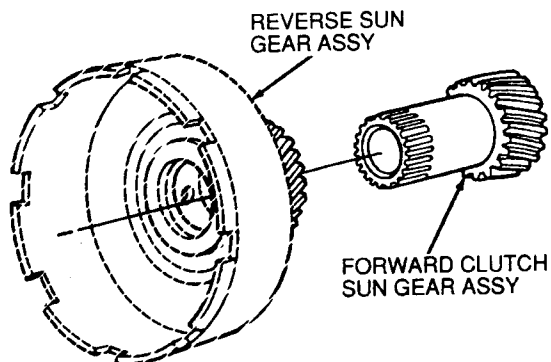

1. Remove the No. 4 needle bearing from drive shell.

NOTE: The sun gear and drive shell is assembled as part of the transmission assembly procedure.

NO. 4 NEEDLE BEARING
DRIVE SHELL
FORWARD CLUTCH

FORWARD SUN GEAR
NO. 5 NEEDLE BEARING
DRIVE SHELL

2. Remove forward sun gear and No. 5 needle bearing from drive shell.

Pump and Intermediate Clutch Piston Disassembly

CONVERTER ASSY 7902
FRONT OIL PUMP SEAL 7D441
BOLT N605789-S100 7 REQ'D
FRONT OIL PUMP BODY ASSY 7A106
OIL PUMP DRIVE GEAR 7H169
BOLT N605787-S52 5 REQ'D
FRONT PUMP SUPPORT ASSY
FRONT OIL PUMP BUSHING 7B258
OIL PUMP DRIVEN GEAR 7H169
FRONT OIL PUMP SEAL ASSY 7A248
FRONT OIL PUMP GASKET 7A136
CONVERTER DRAIN PLUG 87650-S2

1. Remove the No. 1 thrust washer.

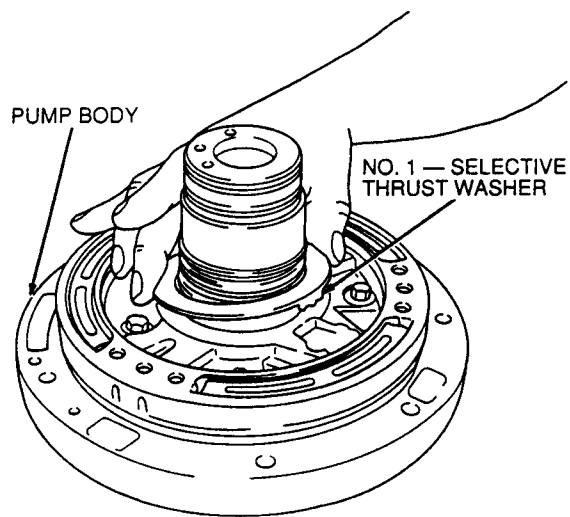

2. Remove five 10mm stator support bolts. Separate stator and pump assembly.

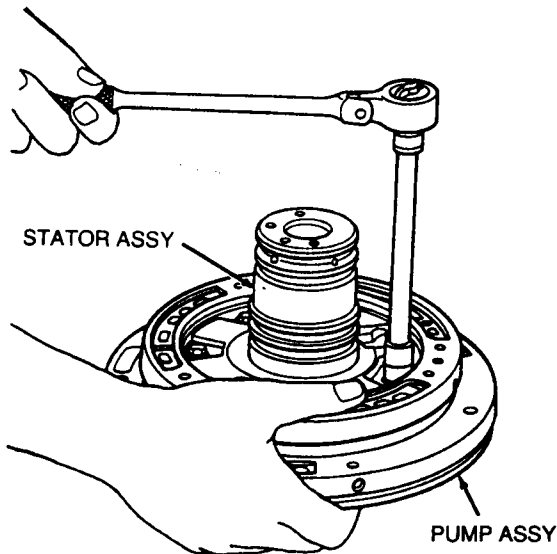

3. Remove four seal rings.

NOTE: The reverse clutch rings are larger than the forward clutch rings.

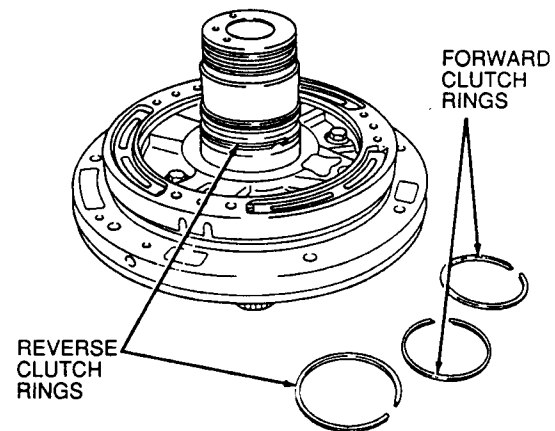

4. Remove drive and driven pump gears from pump body.

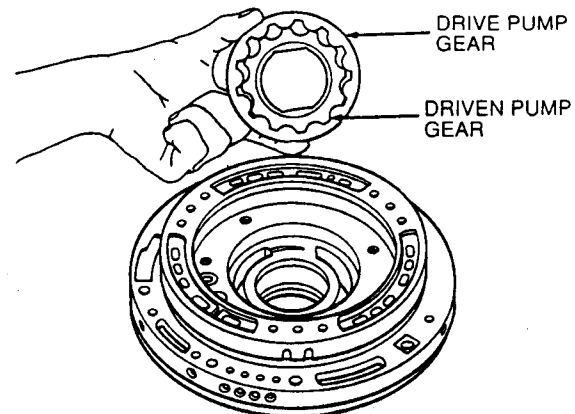

5. Remove spring retainer assembly by carefully dislodging the tabs.

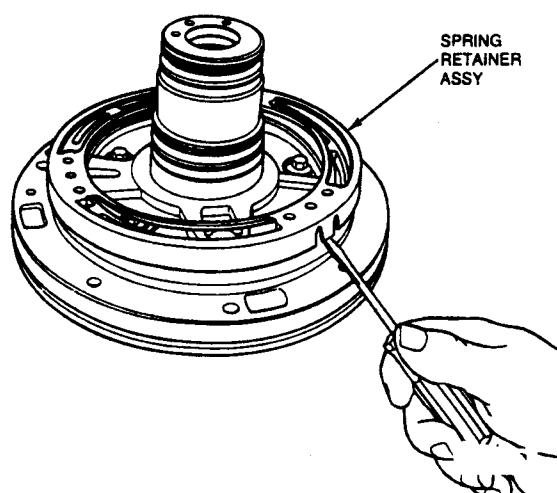

6. Remove clutch piston and inner and outer lip seals.

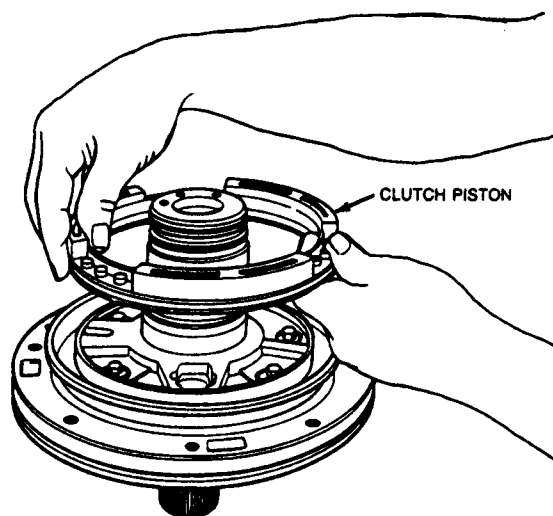

7. Remove pump body-to-case seal and discard.

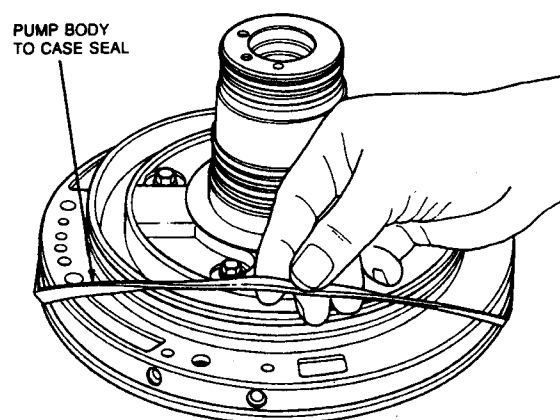

Pump Bushing

Removal and Installation

1. If required, remove bushing using Bushing Remover T80L-77268-B or equivalent.
2. To install, press the bushing using Bushing Installer T80L-77268-A or equivalent.

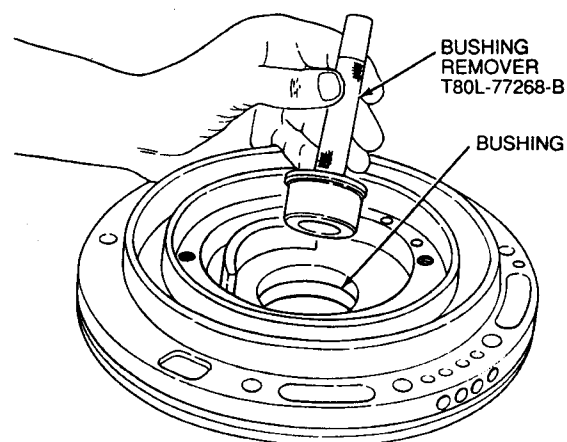

Pump Seal

Installation

1. Install the seal using Front Pump Seal Replacer T63L-77837-A or equivalent.

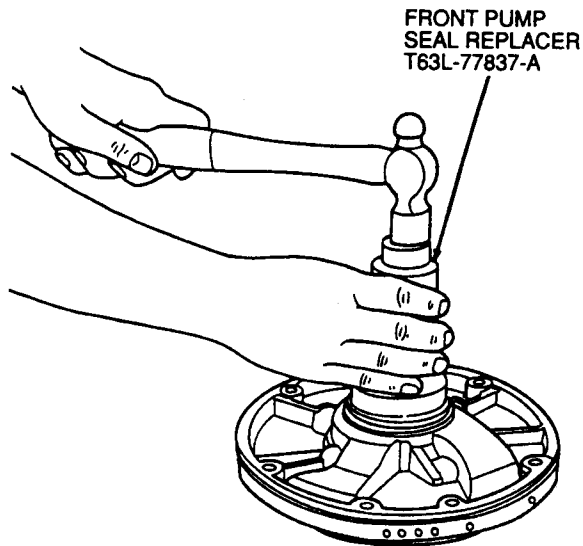

2. Install new inner and outer seals on intermediate clutch piston.

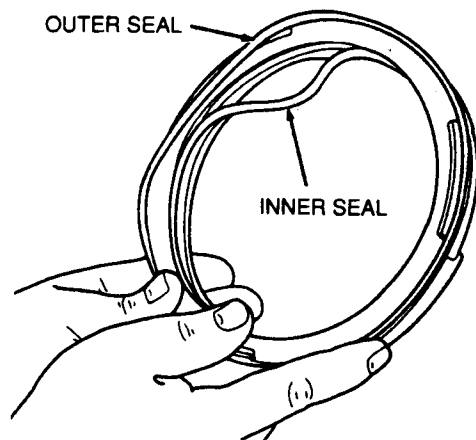

3. Note location of the piston bleed hole.

CAUTION: The piston bleed hole must be located at 12 o'clock position (toward top of transmission).

NOTE: Piston bleed hole is the only round hole in the piston assembly.

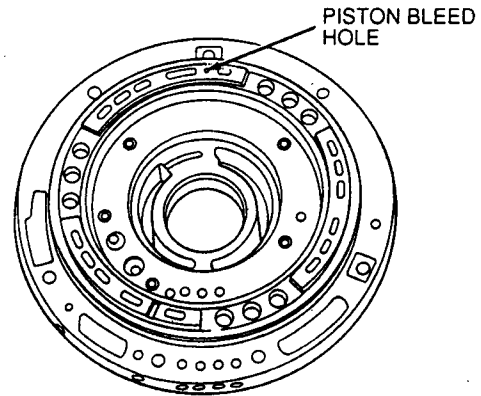

4. Install clutch piston as follows:

NOTE: Coat piston seals and pump body sealing area with petroleum jelly.

- a. Install piston in Seal Protector T80L-77005-A or equivalent.

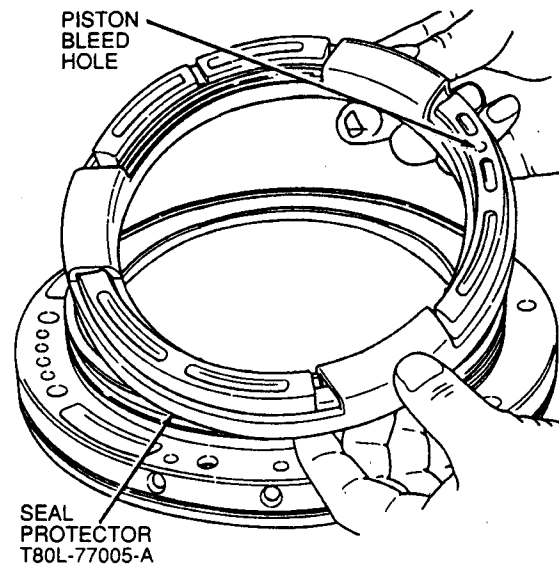

5. Install piston in pump body and push piston to the bottom of the bore by exerting even pressure.

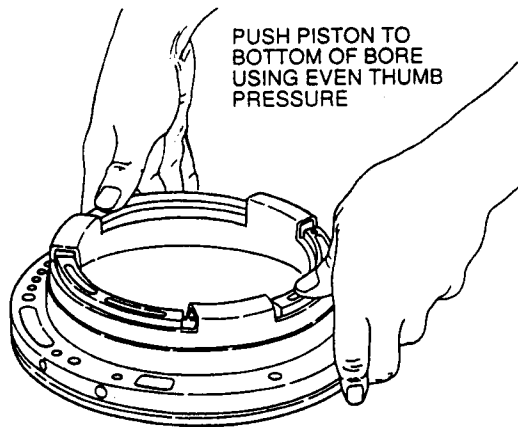

6. Snap spring retainer assembly into place on pump body.

SPRING RETAINER
APPLY EVEN PRESSURE
TO INSTALL

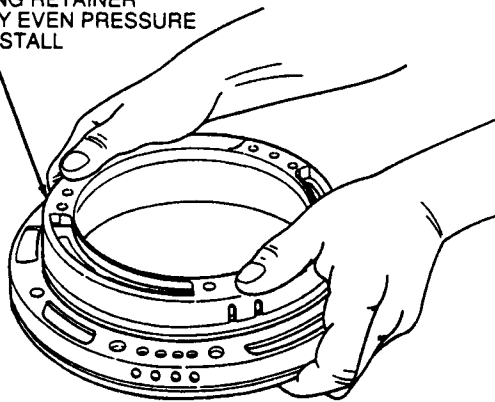

7. Install the drive and driven pump gears in pump body.

The flats have steps that must face the pump body for ease of installing the converter.

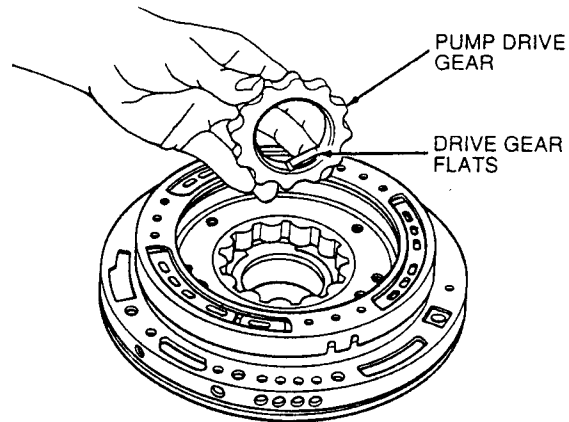

8. Install stator support seal rings.

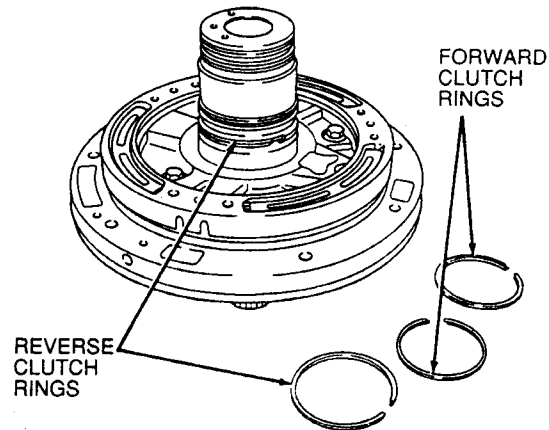

9. Position stator support to pump body and install retaining bolts. Tighten to 16-22 N-m (12-16 lb-ft).

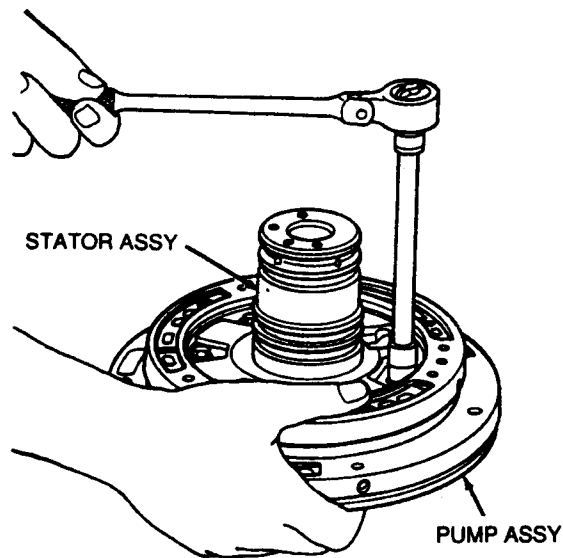

Transmission

Assembly

1. If output shaft bushing was removed, position replacement bushing on Bushing Installer T61L-7657-A or equivalent and install in bushing bore through the front of the case.
2. Thread Impact Slide Hammer T50T-100-A or equivalent into bushing installer through the back of the case. Install the bushing.

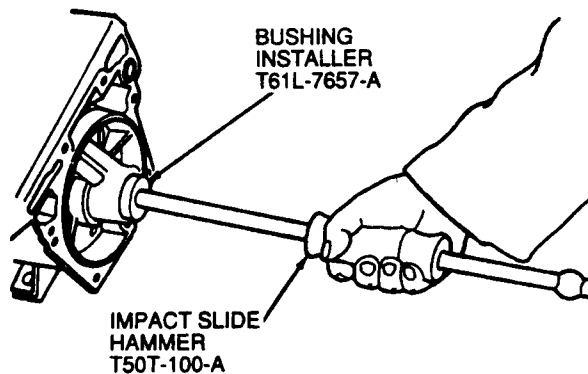

3. With transmission in the vertical position, coat bearing with petroleum jelly and install the No. 9 needle bearing on the transmission case boss.

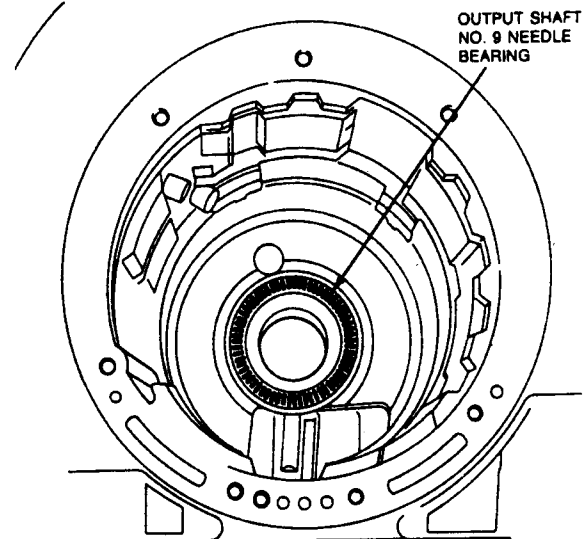

4. Install output shaft, ring gear and direct clutch as an assembly.

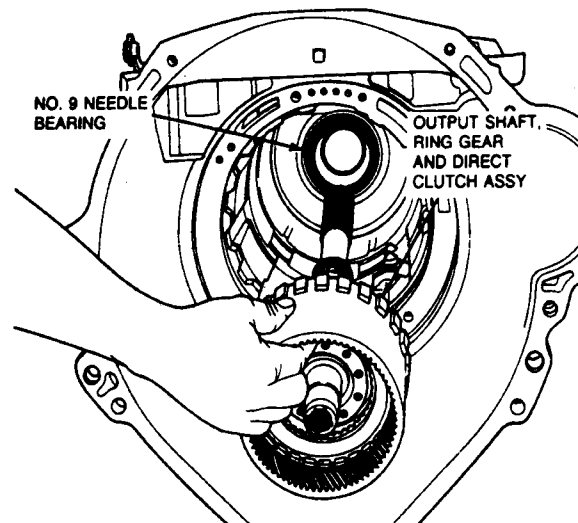

5. Install output shaft retaining snap ring.

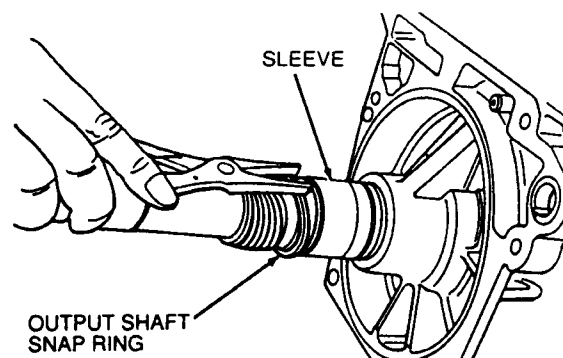

6. Install the low / reverse band. Ensure band is seated on anchor pins.

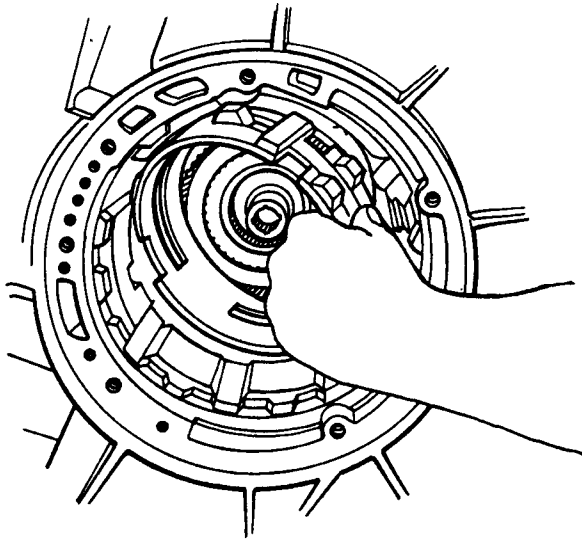

NOTE: Planet carrier and center support assembly cannot be installed unless the notch cut in the center support is aligned with the overdrive band anchor pin. Top of center support should be below snap ring groove.

7. Install planetary assembly and center support as a unit.

Align notch in center support with overdrive band anchor pin.

Rotate the output shaft, if necessary, to align the planet carrier splines with the direct clutch hub splines.

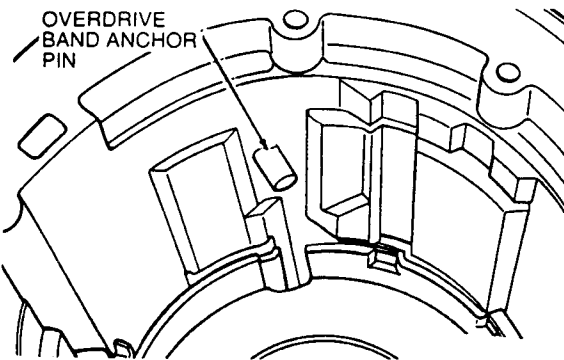

8. Install the center support anti-clunk spring using a screwdriver to position spring.

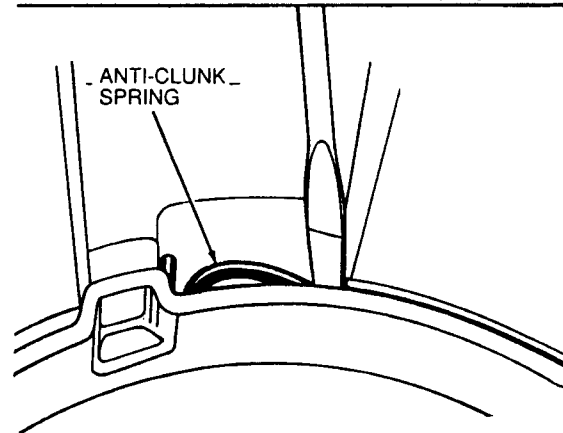
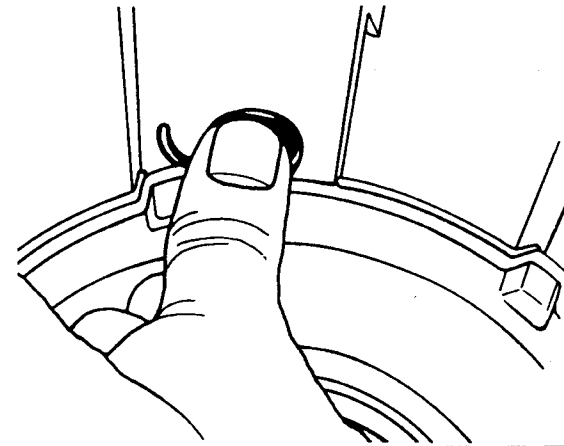

9. Install center support retaining ring. Reference snap ring end tab to anchor pin location.

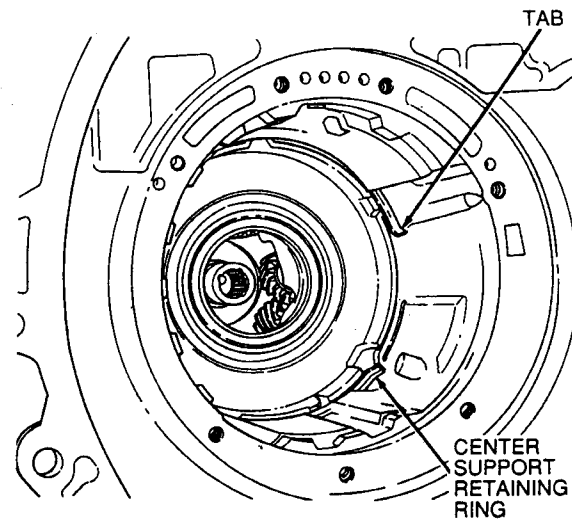

10. Install forward sun gear, No. 5 needle bearing drive shell and No. 4 needle bearing.

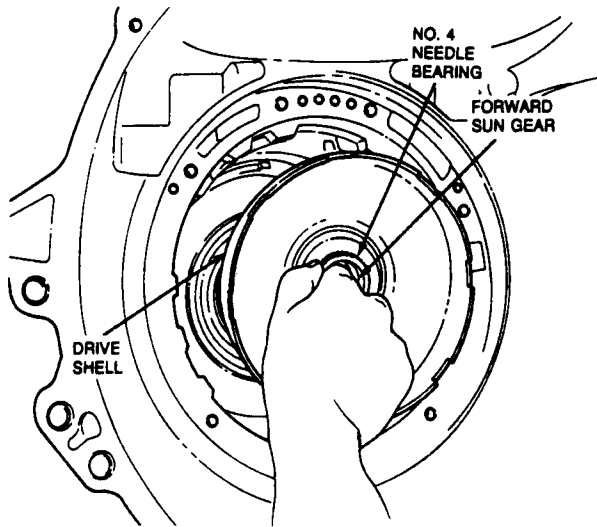

11. Install intermediate stub shaft.

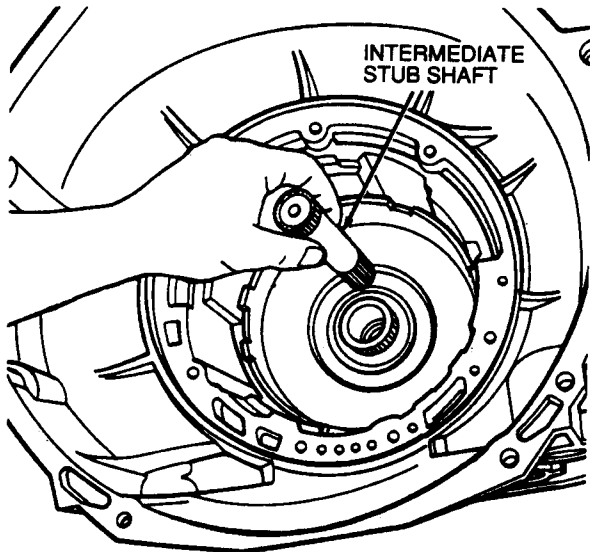

12. Install forward clutch hub and No. 3 needle bearing.

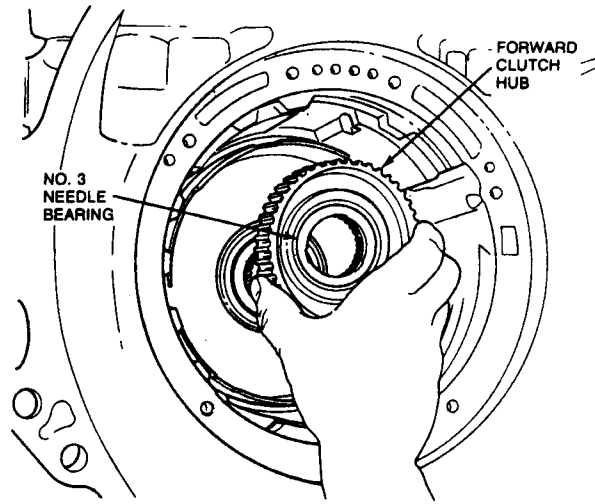

13. Install forward clutch assembly.

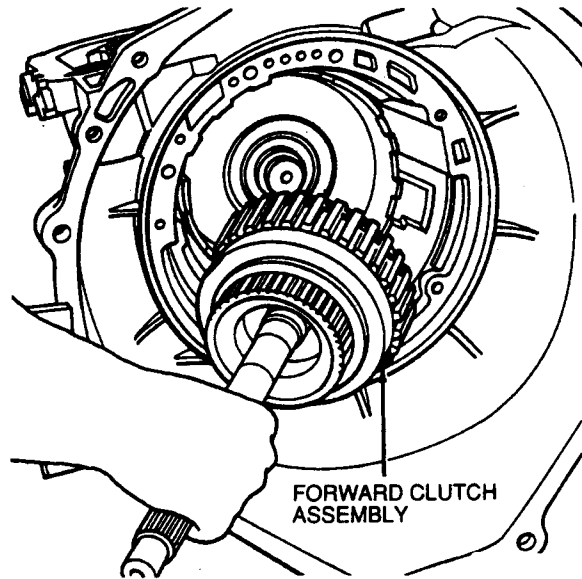

14. Install reverse clutch cylinder assembly.

NOTE: Wiggle the turbine shaft while engaging the reverse clutch splines. Make sure the reverse clutch cylinder lugs are completely seated in the notches of the reverse sun gear and drive shell.

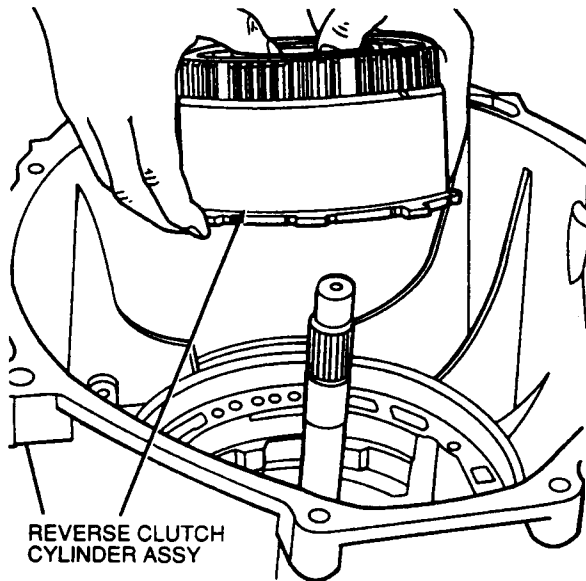

15. Install overdrive band over reverse clutch assembly and position the pocket of the band against anchor pin. Install overdrive servo return spring and overdrive servo piston assembly. Verify tip of piston assembly engages the pocket of overdrive band. Using Servo Piston Remover/Replacer Tool T92P-70023-A or equivalent. Install piston assembly into the case and compress return spring.

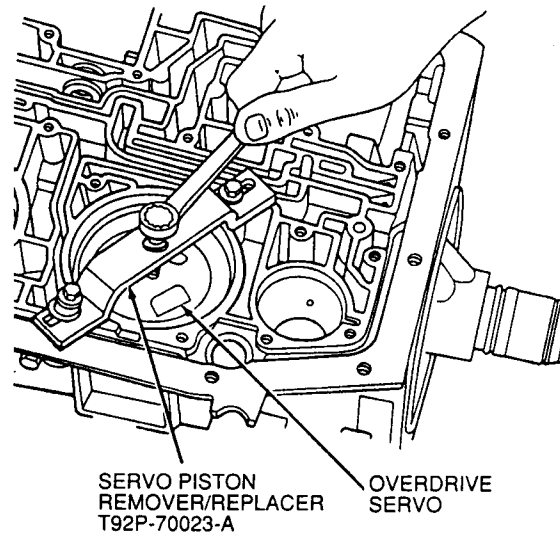
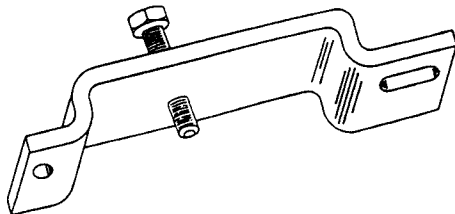

16. Make sure band anchor and tip of the piston assembly are properly positioned against band pockets. Tighten tool forcing screw until piston is below snap ring groove and install snap ring, remove tool.

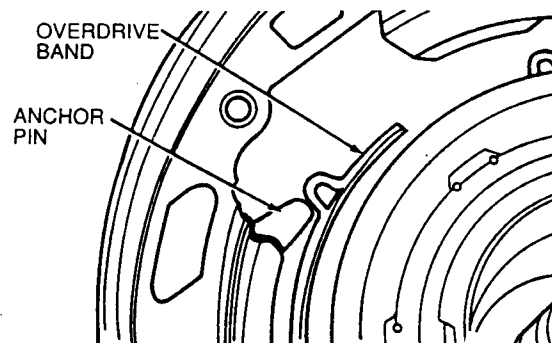

17. Install intermediate clutch as follows:
- Pressure plate is thickest. Install this first with chamfer side down.
 - Clutch plates.

- c. Perform Intermediate Clutch Selective Steel I.C. plate procedure.

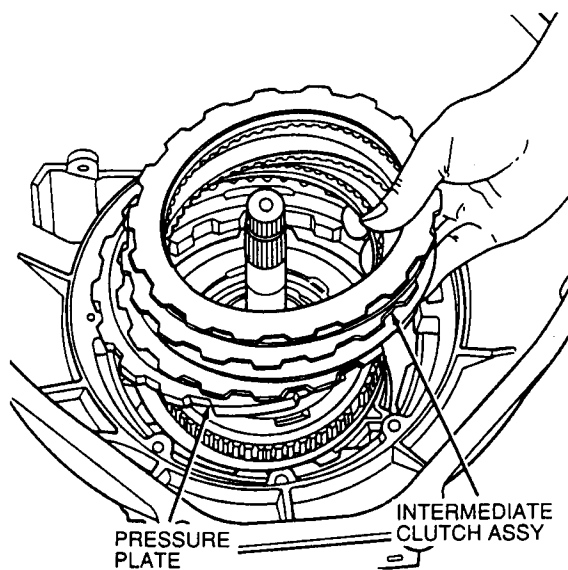

Intermediate Clutch Selective Steel Plate Procedure

18. With proper intermediate plates selected and installed, perform end clearance check for No. 7 thrust washer using the same tools.

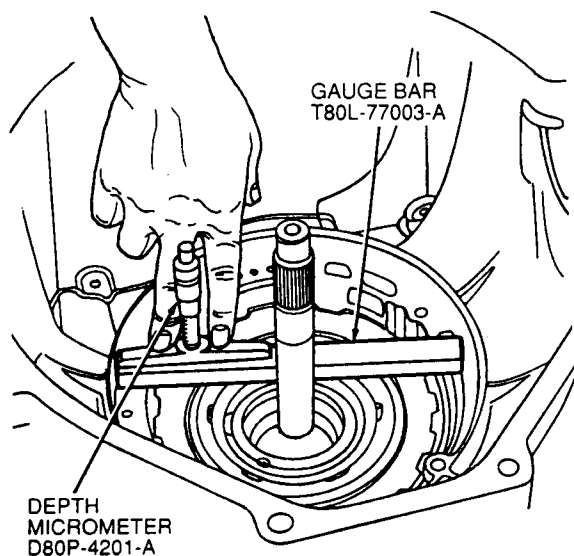

19. Measure the intermediate clutch clearance using Depth Micrometer D80P-4201-A and Gauge Bar T80L-77003-A or equivalent.

Set the gauge bar across the pump case mounting surfaces. The depth at the intermediate clutch separator plate is:

- 41.5-41.8mm (1.634-1.636 inch)

Check the clearance again 180 degrees opposite to ensure the average depth is within tolerance.

NOTE: Maintain downward pressure on clutch pack while measuring depth.

If the depth is not within tolerance, the following size selective steel plates are available:

- 1.80-1.7mm (0.071-0.067 inch)
- 2.05-1.95mm (0.081-0.077 inch)
- 2.31-2.20mm (0.091-0.087 inch)
- 2.56-2.46mm (0.101-0.097 inch)

Install correct plate and check clearance.

Transmission Selective Thrust Washer Procedure

20. Position the Depth Micrometer D80P-4201-A on Gauge Bar T80L-77003-A or equivalent so that the depth is measured at the reverse clutch drum thrust face. Check the end play 180 degrees opposite to determine the average depth.

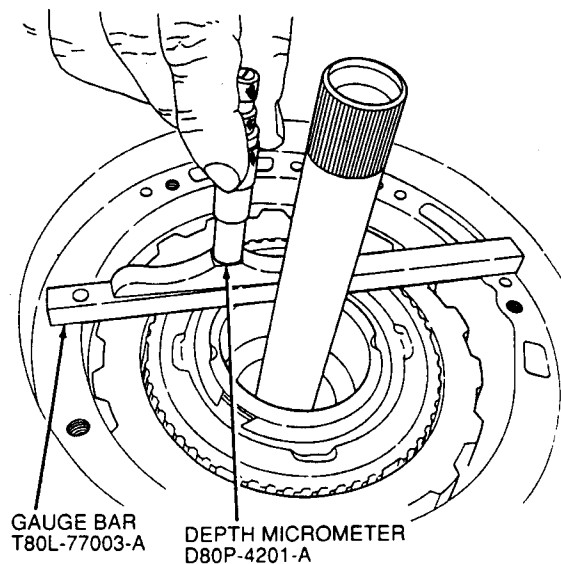

21. Install No. 1 selected thrust washer on pump body using petroleum jelly to hold in place.

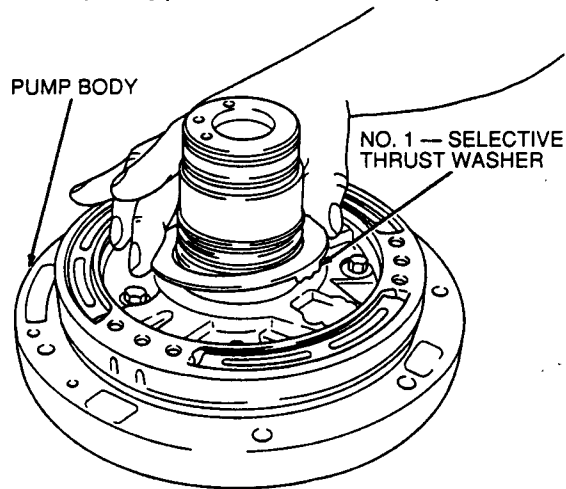

22. Install pump-to-case gasket. Make sure gasket is positioned and case passages are covered.
23. To maintain pump-to-case alignment, use a fabricated M8-1.25mm bolt (head removed) as a guide. Install in the 12 o'clock position using petroleum jelly on pump-to-case seal surfaces to aid pump installation.

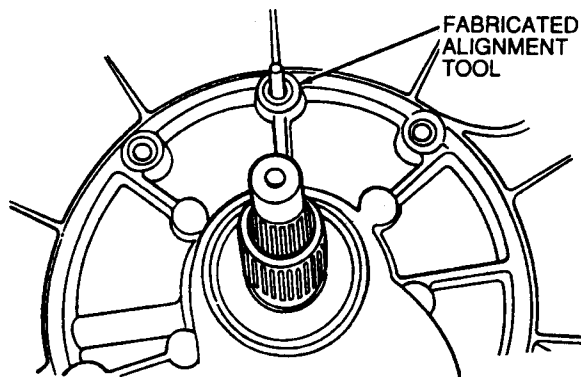

24. To aid assembly, grasp turbine shaft and wiggle shaft while pressing down on pump.

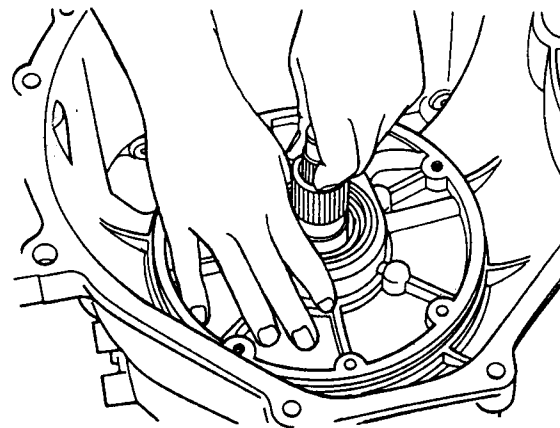

25. Remove alignment bolt and install pump-to-case bolts. Alternate bolt tightening to "draw" the pump fully into the case. Tighten to 22-27 N·m (16-20 lb-ft).

Place transmission in the horizontal position.

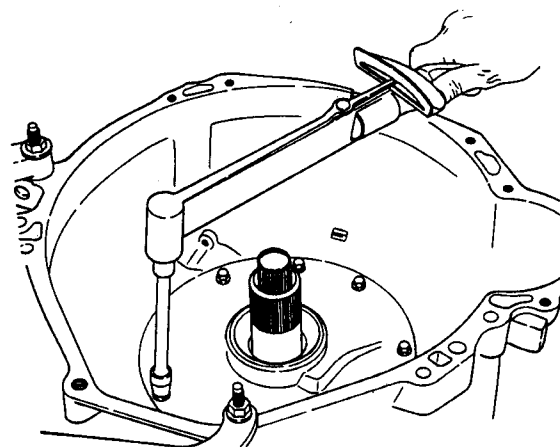

26. Install output shaft speed sensor.

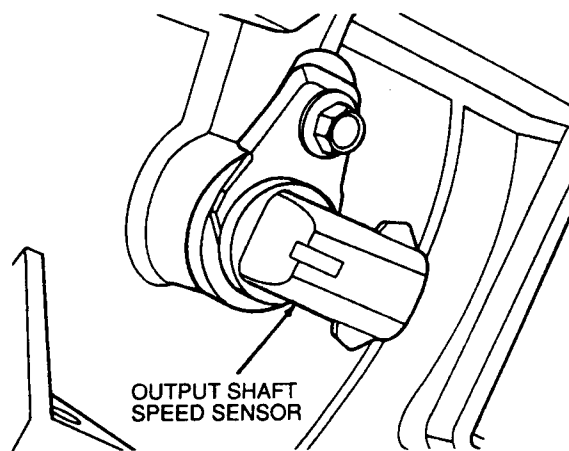

27. Install manual lever seal using Shift Lever Seal Replacer T74P-77498-A or equivalent.

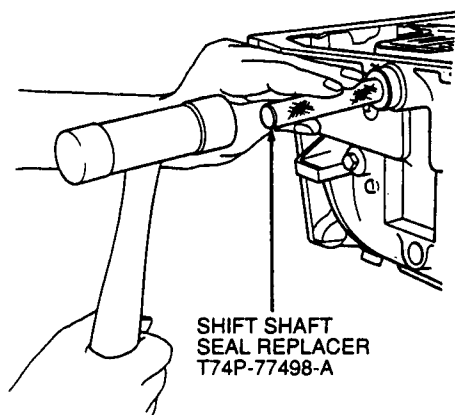

28. Install EPC.



29. Install park pawl and return spring. Slide shaft into case through pawl.

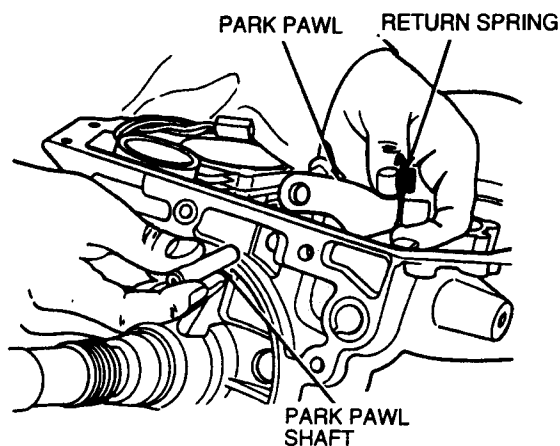

30. Install new tailshaft housing gasket and tailshaft housing. Tighten bolts to 21-27 N·m (16-20 lb-ft).
31. Install tailshaft housing output shaft seal.
32. Position detent and park rod assembly into case. Park rod must be positioned over pawl.

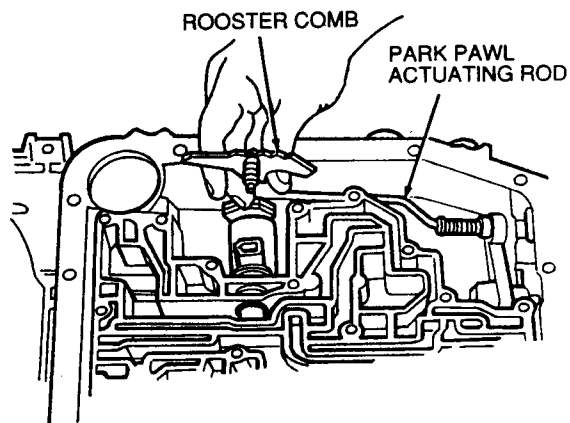

33. Slide manual lever into case and position through detent. Install nut and tighten to 26-37 N·m (20-27 lb-ft).
34. Install tapered roll pin.
35. Install filter into case, (head first).

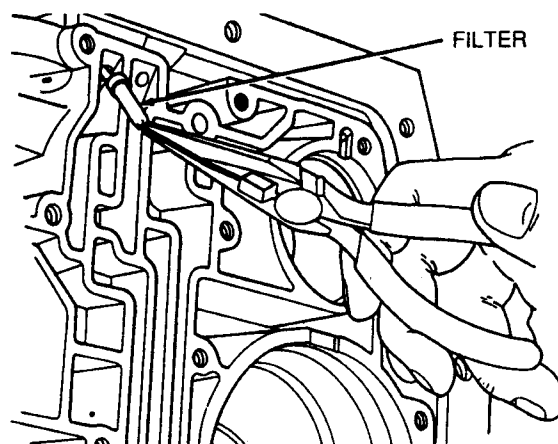

36. Install reverse band spring, piston and rod assembly, cover and snap ring.

37. Tighten screw on Servo Piston Remover / Replacer T92P-70023-A or equivalent, to allow enough clearance to install snap ring.

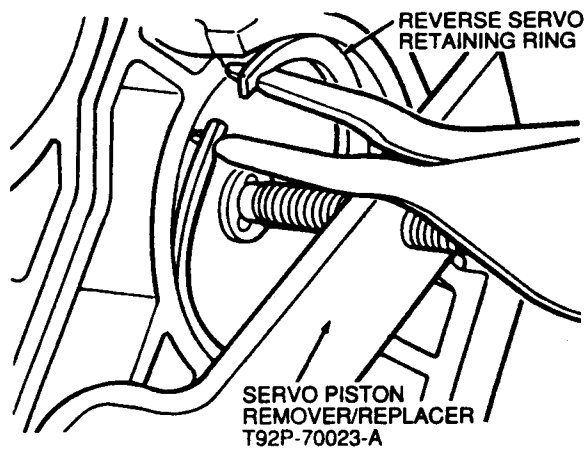

38. Install new piston O-ring seals on 2-3 accumulator and 1-2 accumulator. Install 2-3 accumulator.

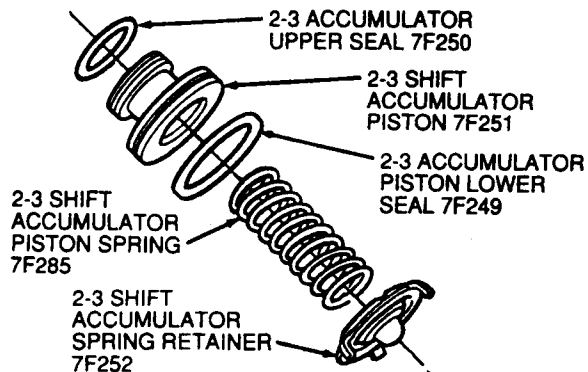

39. Install the following components:

- Large spring
- New piston O-ring seals
- Piston
- Small spring
- Cover with new seals
- 1-2 accumulator

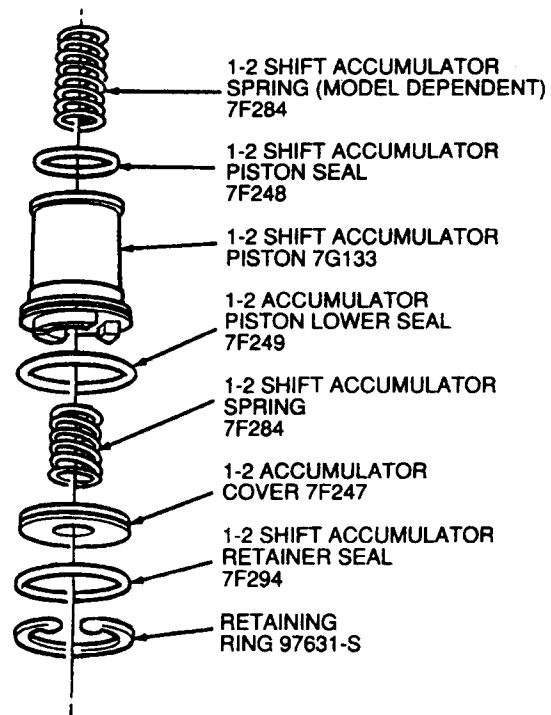

40. Align and install wire harness into case. Inspect O-ring and replace if required.

NOTE: Tab on connector is secured by main control.

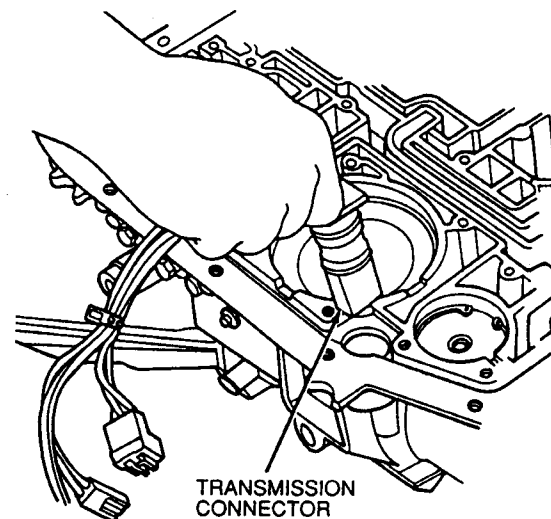

AOD-E

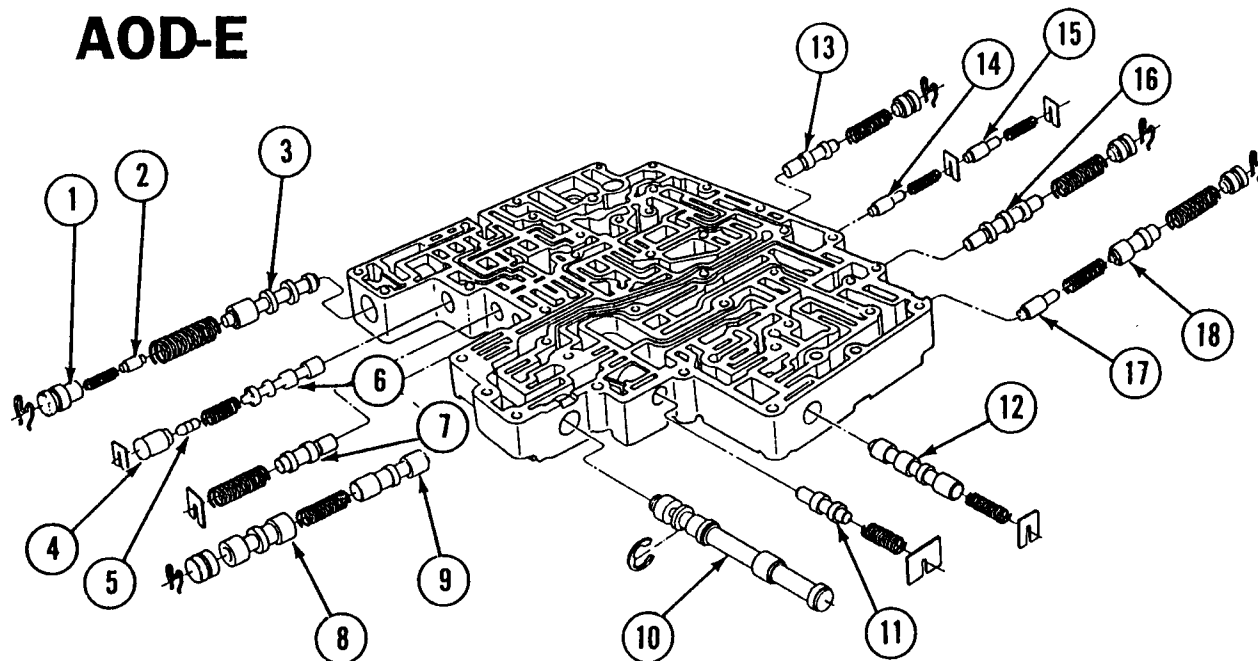

1. MAIN OIL PRESSURE BOOSTER SLEEVE
2. MAIN OIL PRESSURE BOOSTER VALVE
3. MAIN REGULATOR VALVE
4. BYPASS CLUTCH CONTROL PLUNGER SLEEVE
5. BYPASS CLUTCH CONTROL PLUNGER VALVE
6. BYPASS CLUTCH CONTROL VALVE
7. CONVERTER PRESSURE LIMIT VALVE
8. 2-3 SHIFT VALVE
9. 1-2 SHIFT VALVE

10. MANUAL VALVE
11. SOLENOID PRESSURE REGULATOR VALVE
12. 2-3 BACKOUT VALVE
13. OVERDRIVE SERVO REGULATOR VALVE
14. 3-4 CAPACITY MODULATOR VALVE
15. LOW SERVO MODULATOR VALVE
16. 3-4 SHIFT VALVE
17. 2-3 CAPACITY MODULATOR VALVE
18. ORIFICE CONTROL VALVE

	GEAR	SOLENOIDS		MODULATED CONVERTER CLUTCH CONTROL SOLENOID	EPC SOLENOID
		SS1	SS2		
OVERDRIVE RANGE	1	ON	OFF	CLUTCH HYDRAULICALLY DISABLED	PRESSURE OUTPUT CONTROLLED BY EEC-IV STRATEGY IN ALL RANGES
	2	OFF	OFF	CONTROLLED BY EEC-IV STRATEGY	
	3	OFF	ON		
	4	ON	ON		
D RANGE	1	ON	OFF	CLUTCH HYDRAULICALLY DISABLED	
	2	OFF	OFF	CONTROLLED BY EEC-IV STRATEGY	
	3	OFF	ON		
"1" RANGE	1	ON	OFF	CLUTCH HYDRAULICALLY DISABLED	
	2	OFF	OFF	CONTROLLED BY EEC-IV STRATEGY	
REVERSE, PARK NEUTRAL	-	ON	OFF	CLUTCH HYDRAULICALLY DISABLED	

41. Position main control using the two alignment bolts as a guide. Ensure main control check balls are in the correct locations.

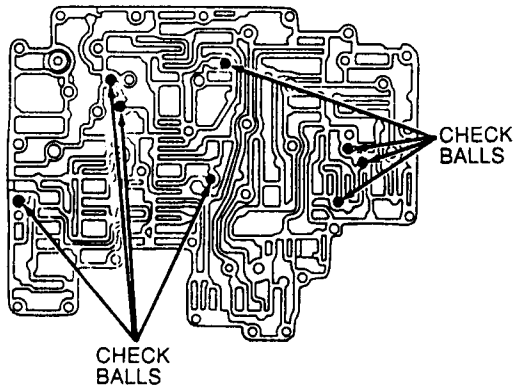

42. Install the EPC solenoid bracket. Loosely install one long 6mm bolt.

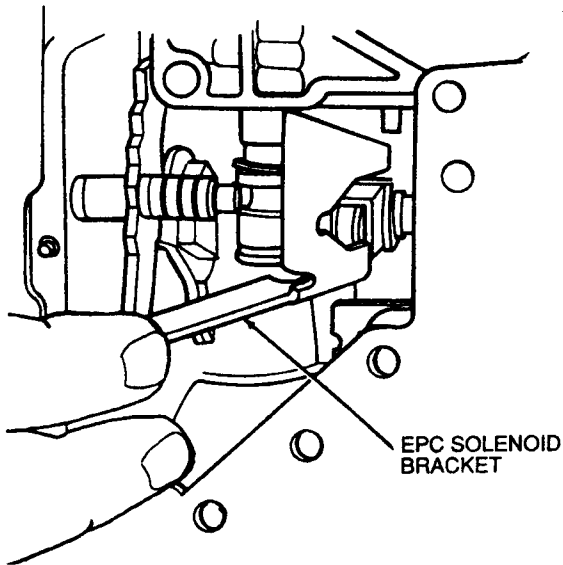

43. Loosely install 11 long 6mm bolts and 12 short.

44. Install detent spring and roller and one short 8mm bolt.

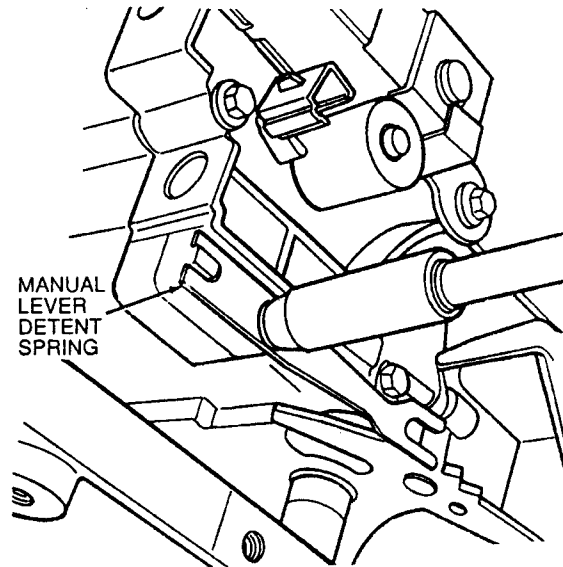

45. Tighten main control bolts to 8-11 N·m (71-97 lb-in).

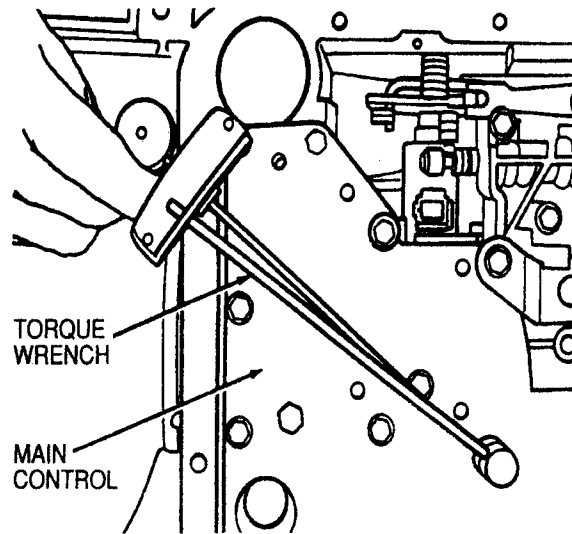

46. Connect wiring harness.

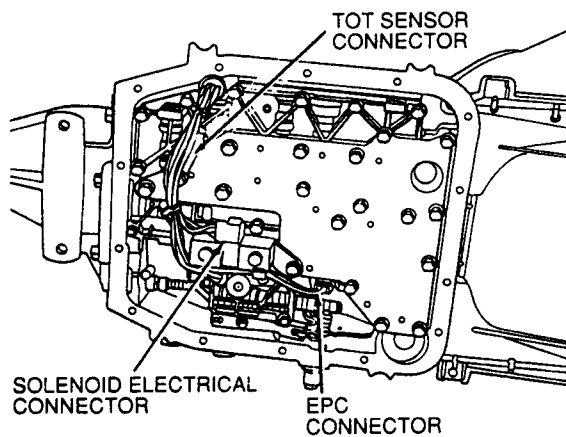

47. Install new filter and grommet.

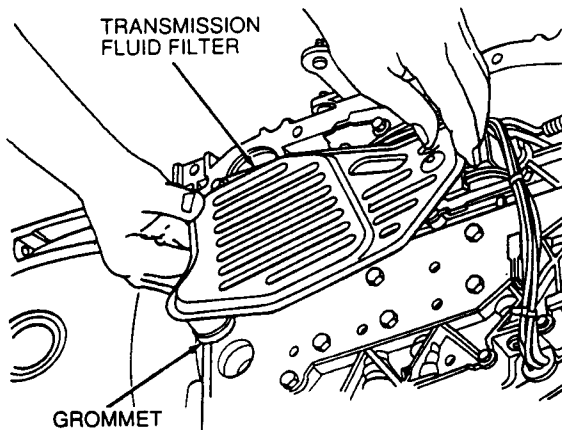

48. Install MLPS on manual lever and loosely install bolts.

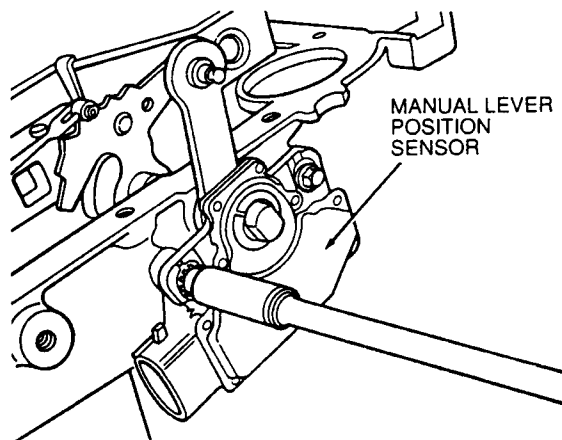

49. Position manual lever in NEUTRAL.

NOTE: Park is the last detent when the manual lever is full forward. Return two detents toward output shaft for neutral.

Install MLPS adjustment tool. Insert Gear Position Sensor Adjuster T71P-70010-A or equivalent into slots. Align all three slots on MLPS with three tabs on tool.

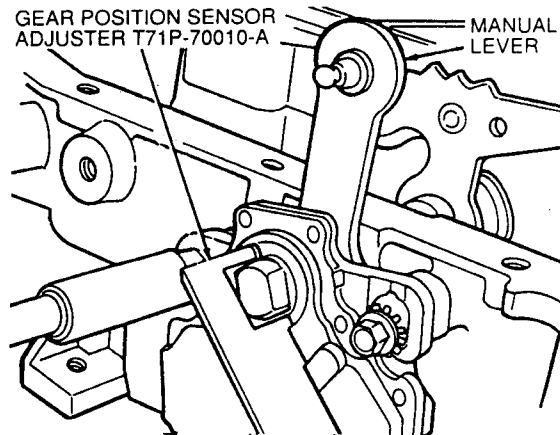

50. Tighten MLPS bolts to 7-10 N-m (62-88 lb-in).

51. Install new pan gasket and oil pan. Tighten all bolts to 12-15 N-m (107-132 lb-in).

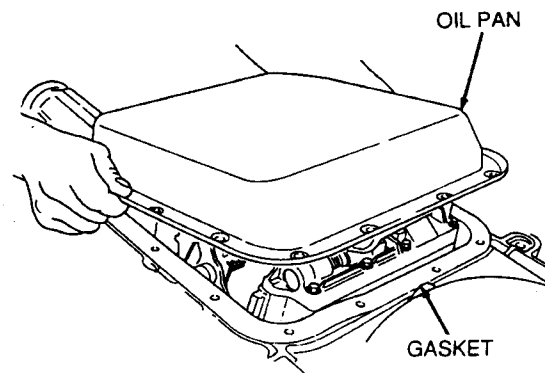

CLEANING AND INSPECTION

Transmission

Clean all parts with suitable solvent and use moisture-free air to dry off all parts and clean out fluid passages.

NOTE: The composition clutch plates, bands and synthetic seals should not be cleaned in a vapor degreaser or with any type of detergent solution.



Technical Service Information

SPECIFICATIONS

NOTE: Piston travel can be adjusted using one of the selective servo pistons available for service.

SELECTIVE SERVO PISTONS — ALL MODELS

Rod Length ¹⁶	I.D.
2.936	1 Groove
2.989	2 Groove
3.043	3 Groove

TRANSMISSION END PLAY

NOTE: Transmission end play can be adjusted using one of the selective thrust washers available for service. After measuring the depth, install the required thrust washer.

CONVERTER END PLAY

Transmission	New or Rebuilt	Used
All	0.58mm (0.023 inch)	1.27mm (0.050 inch)

SELECTIVE THRUST WASHER¹⁷ — ALL MODELS

Depth	Thickness	Color Code	Depth	Thickness	Color Code
36.7342-38.1838mm (1.4856-1.5033 inch)	1.217-1.371mm (0.050-0.054 inch)	Green	39.0754-39.5046mm (1.5384-1.5553 inch)	2.590-2.692mm (0.102-0.106 inch)	Red
38.1864-38.641mm (1.5034-1.5213 inch)	1.727-1.828mm (0.068-0.072 inch)	Yellow	39.5072-40.1396mm (1.5554-1.5803 inch)	3.022-3.124mm (0.119-0.123 inch)	Blue
38.6436-39.0728mm (1.5214-1.5383 inch)	2.159-2.260mm (0.085-0.089 inch)	Natural			

TORQUE SPECIFICATIONS

Description	N-m	Lb-In
Manual Lever Position Sensor Retaining Bolts	7-10	62-88
Tail Shaft Housing Bolts	21-27	16-20 (Lb-Ft)
Oil Pan Retaining Bolts	12-15	107-132
Stator Support-to-Pump Body	20-26	15-19 (Lb-Ft)
Main Control Bolts	8-10	71-97

OVERDRIVE SERVO

Dia.	Code	Stroke
2.7 Inch	A	1.676-5.332mm (0.066-0.210 Inch)

CLUTCH AND BAND APPLICATION

	Interim Friction Clutch	Interim One-Way Clutch	Overdrive Band	Reverse Clutch	Forward Clutch	Planetary One-Way Clutch	Low-Reverse Band	Direct Clutch
1st Gear Manual Low					Applied	Holding	Applied	
2nd Gear Manual Low	Applied	Holding	Applied		Applied			
1st Gear — Ⓢ(OVERDRIVE) or D(3)					Applied	Holding		
2nd Gear — Ⓢ(OVERDRIVE) or D(3)	Applied	Holding			Applied			
3rd Gear — Ⓢ(OVERDRIVE) or D(3)	Applied				Applied			Applied
4th Gear — Ⓢ(OVERDRIVE)	Applied		Applied				Applied	
Reverse (R)				Applied			Applied	

¹⁶ Measured from the piston surface to the end of the rod.

¹⁷ The thrust washer is located on the stator support which is attached to the back of the pump housing.